

Inductive Proximity Sensor

TL-T

Miniature, Slim-styled Proximity Sensor

- Space-saving Sensor ideal for timing cam and dog detection.
- Four mounting holes provided: two each mounting from side or rear of the housing.
- Ganged mounting possible for multiple pulse generation.
- Two basic types available: Shielded type offers 2-mm sensing distance and non-shielded type offers 5-mm sensing distance.

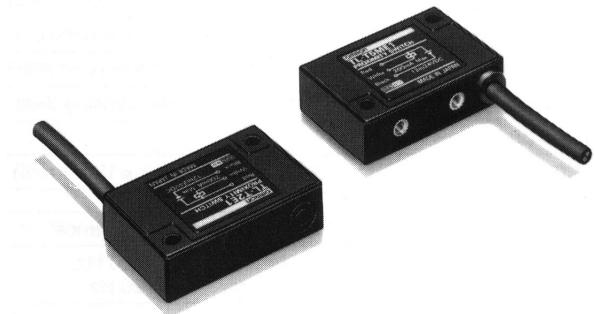

Ordering Information

Shield	Sensing distance	DC 3-wire models				Response frequency	AC 2-wire models		
		NPN		PNP			NO	NC	Response frequency
		NO	NC	NO	NC				
Shielded	2 mm	TL-T2E1	TL-T2E2	TL-T2F1	TL-T2F2	800 Hz	TL-T2Y1	TL-T2Y2	20 Hz
Unshielded	5 mm	TL-T5ME1	TL-T5ME2	TL-T5MF1	TL-T5MF2	250 Hz	TL-T5MY1	TL-T5MY2	

Specifications

■ Ratings/Characteristics

Item	TL-T2E1, TL-T2E2, TL-T2F1, TL-T2F2	TL-T2Y1, TL-T2Y2	TL-T5ME1, TL-T5ME2, TL-T5MF1, TL-T5MF2	TL-T5MY1, TL-T5MY2
Supply voltage (operating voltage range)	E and F models: 12 to 24 VDC (10 to 30 VDC), ripple (p-p): 20% max. Y models: 100 to 220 VAC (90 to 250 VAC), 50/60 Hz			
Current consumption	E and F models: 15 mA max. at 24 VDC			
Leakage current	Y models: 2.5 mA max. at 200 VAC			
Sensing object	Magnetic metal (The sensing distance decreases with non-magnetic metal.)			
Sensing distance	2 mm ±10%		5 mm ±10%	
Sensing distance (standard object)	0 to 1.6 mm (iron, 12 x 12 x 1 mm)		0 to 4 mm (iron, 15 x 15 x 1 mm)	
Differential travel	10% max. of sensing distance			
Response frequency	E and F models: 800 Hz, Y models: 20 Hz		E and F models: 250 Hz, Y models: 20 Hz	
Operating status (with sensing object approaching)	E1 models: L output signal with load ON E2 models: H output signal with load OFF F1 models: H output signal with load ON Y1 models: Load ON Y2 models: Load OFF			
Control output (switching capacity)	E and F models: 100 mA max. at 12 VDC and 200 mA max. at 24 VDC Y models: 10 to 200 mA			
Circuit protection	E and F models: Reverse connection protection and surge absorber Y models: Surge absorber			
Ambient temperature	Operating: -25°C to 70°C (with no icing)			
Ambient humidity	Operating: 35% to 95%			
Temperature influence	±10% max. of sensing distance at 23°C in the temperature range of -25°C to 70°C			
Voltage influence	E and F models: ±2.5% max. of sensing distance within a range of ±15% of the rated power supply voltage Y models: ±2.5% max. of sensing distance within a range of ±10% of the rated power supply voltage			
Residual voltage	E and F models: 1.0 V max. with a load current of 100 mA and a cord length of 2 m Y models: Refer to <i>Residual Load Voltage (Typical)</i> on page 3.			
Insulation resistance	50 MΩ min. (at 500 VDC) between case and current carry parts			
Dielectric strength	DC switching models: 1,000 VAC, 50/60 Hz for 1 min between case and current carry parts AC switching models: 2,000 VAC, 50/60 Hz for 1 min between case and current carry parts			
Vibration resistance	10 to 55 Hz, 1.5-mm double amplitude for 2 hours each in X, Y, and Z directions			
Shock resistance	500 m/s ² (approx. 50G) for 10 times each in X, Y, and Z directions			
Enclosure rating	IEC IP67			
Weight (with 2-m cord)	Approx. 70 g			
Material	Case	Heat-resistant ABS resin		
	Sensing surface	Heat-resistant ABS resin		

Engineering Data

Operating Range (Typical)

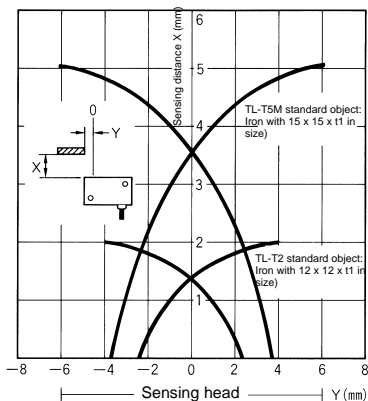

Sensing Object Size and Material vs. Sensing Distance (Typical)

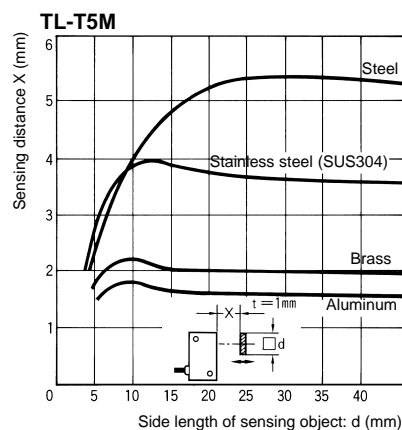
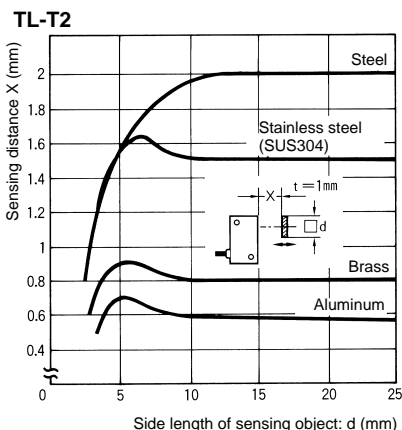

Leakage Current (Typical)

TL-T□Y

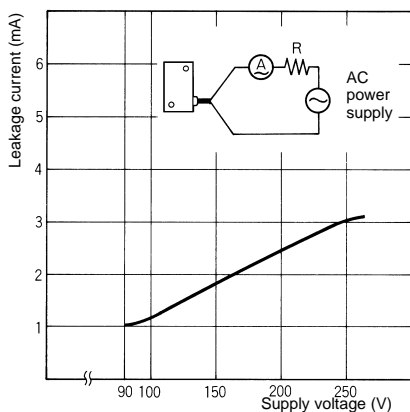

Residual Load Voltage (Typical) (at constant 100 VAC)

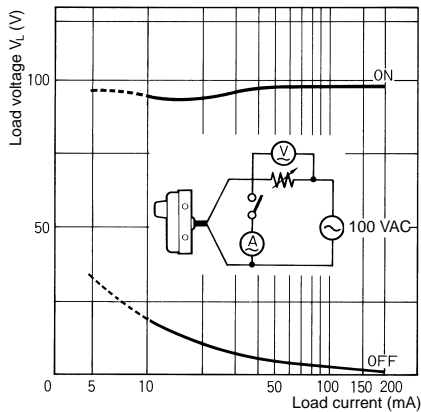

(at constant 200 VAC)

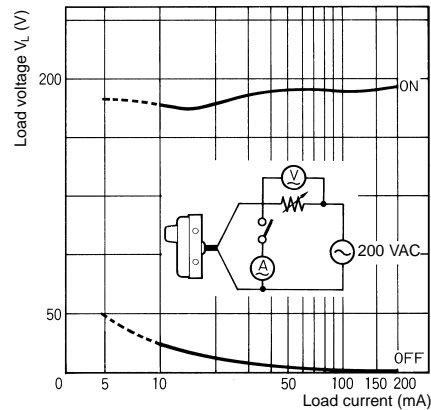

Operation

Output Circuits

Note: The lead wire colors of the TL-T have been changed in compliance with the latest Japanese Industrial Standards. Colors in parentheses are previous ones.

E Models

NPN (DC 3-wire)

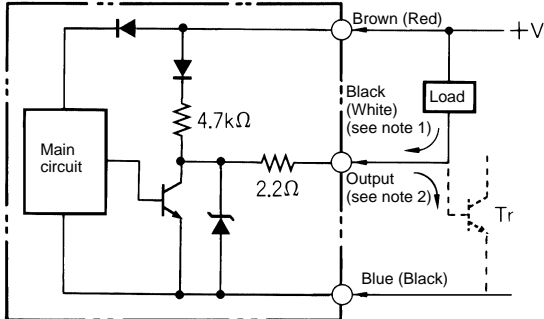

- Note:**
1. 200 mA max. (load current)
 2. When a transistor is connected

F Models

PNP (DC 3-wire)

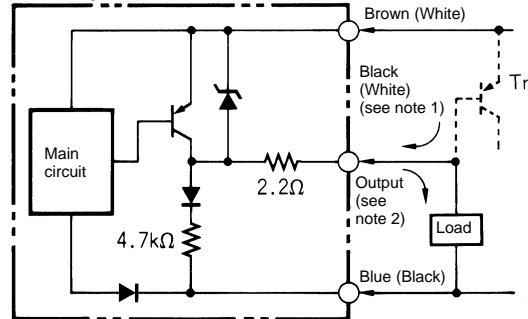

- Note:**
1. 200 mA max. (load current)
 2. When a transistor is connected

Y Models

(AC 2-wire)

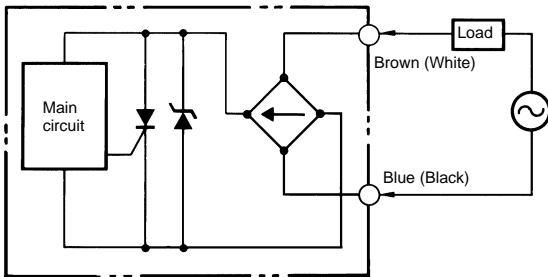

■ Timing Charts

E Models

NPN (DC 3-wire)

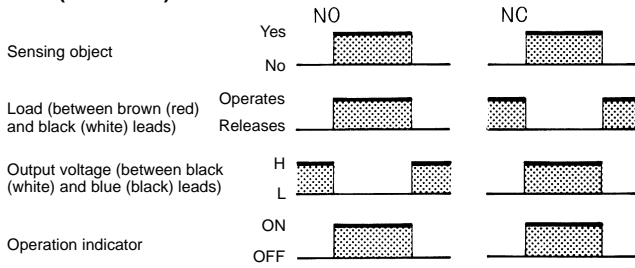

F Models

PNP (DC 3-wire)

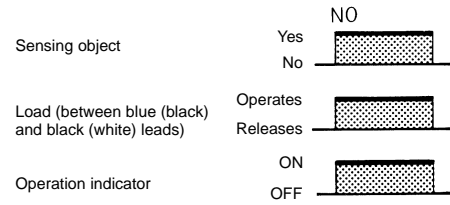

Y Models

(DC 2-wire)

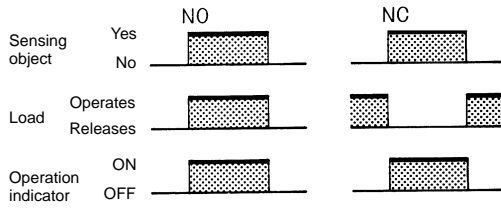

Dimensions

Note: All units are in millimeters unless otherwise indicated.

Weight: Approx. 70 g

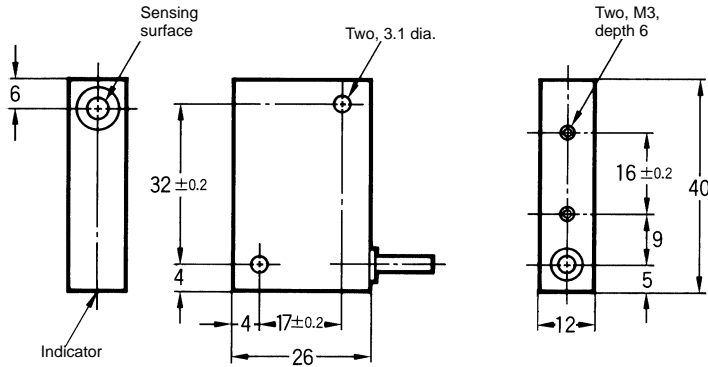

DC switching model: Three, 0.2-mm conductors
 AC switching model: Two, 0.3-mm conductors
 Oil- and vibration-resistant, vinyl-insulated round cord,
 4 external dia.; standard length: 2m

Precautions

Correct Use

Connection to the Load

Be sure to connect the Proximity Sensor to the power source through a load. Direct connection of the Sensor may damage the Sensor.

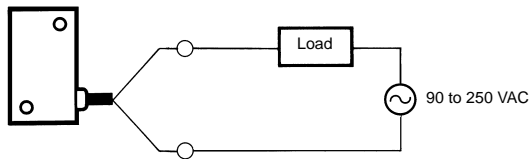

Mounting

At the time of rear mounting, be sure that the tightening torque does not exceed 6 kgf • cm (0.59 N • m).

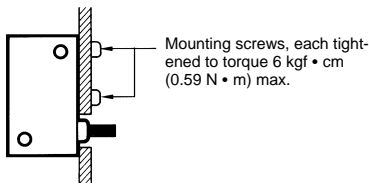

At the time of side mounting, be sure that the tightening torque does not exceed 8 kgf • cm (0.78 N • m).

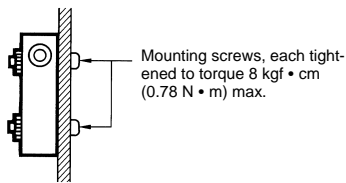

Effect of Surrounding Metals

If the TL-T5M is embedded in metal, keep at least the following distances between the TL-T and the metal.

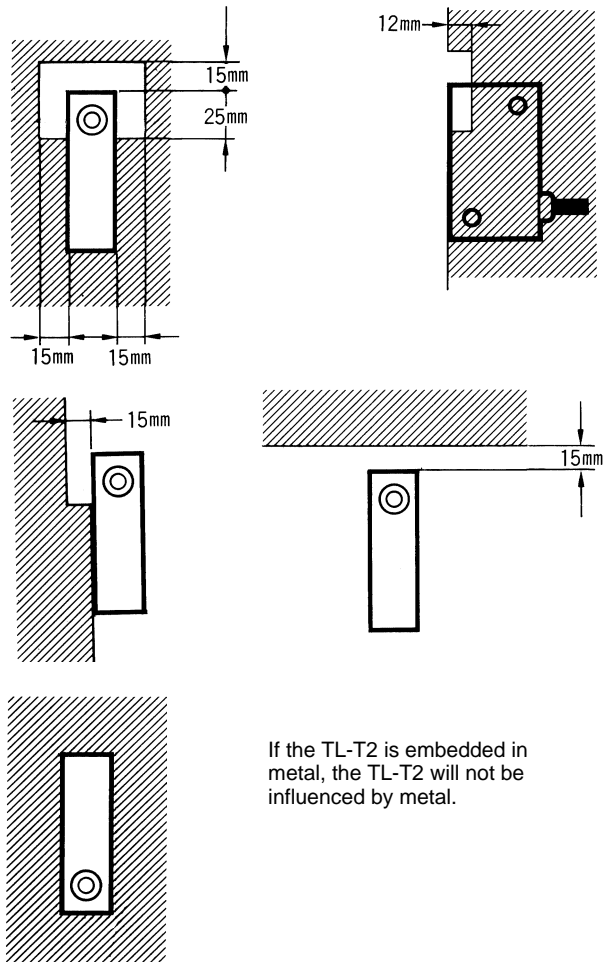

If the TL-T2 is embedded in metal, the TL-T2 will not be influenced by metal.

Mutual Interference

When two or more TL-Ts are mounted face-to-face or side-by-side, separate them as shown below. The table below indicates the minimum distances A and B.

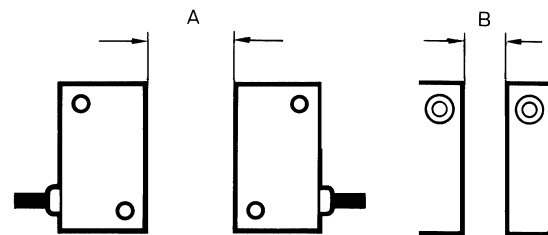

(Unit: mm)

Distance	Model	
	TL-T2	TL-T5
A	40 (10)	120 (60)
B	12 (0)	80 (40)

Note: Figures in parentheses will apply if the Sensors in use are different from each other in response frequency.

ALL DIMENSIONS SHOWN ARE IN MILLIMETERS.

To convert millimeters into inches, multiply by 0.03937. To convert grams into ounces, multiply by 0.03527.

Cat. No. D08-E1-5 **In the interest of product improvement, specifications are subject to change without notice.**

OMRON Corporation

Systems Components Division H.Q.
28th Fl., Crystal Tower Bldg.
1-2-27, Shiromi, Chuo-ku,
Osaka 540 Japan
Phone: 06-949-6012 Fax: 06-949-6021

Printed in Japan
0997-0.5M Ⓐ