

sCompact Square Inductive Proximity Sensor

# E2S

*World's Smallest Square Sensor with Built-in Amplifier*

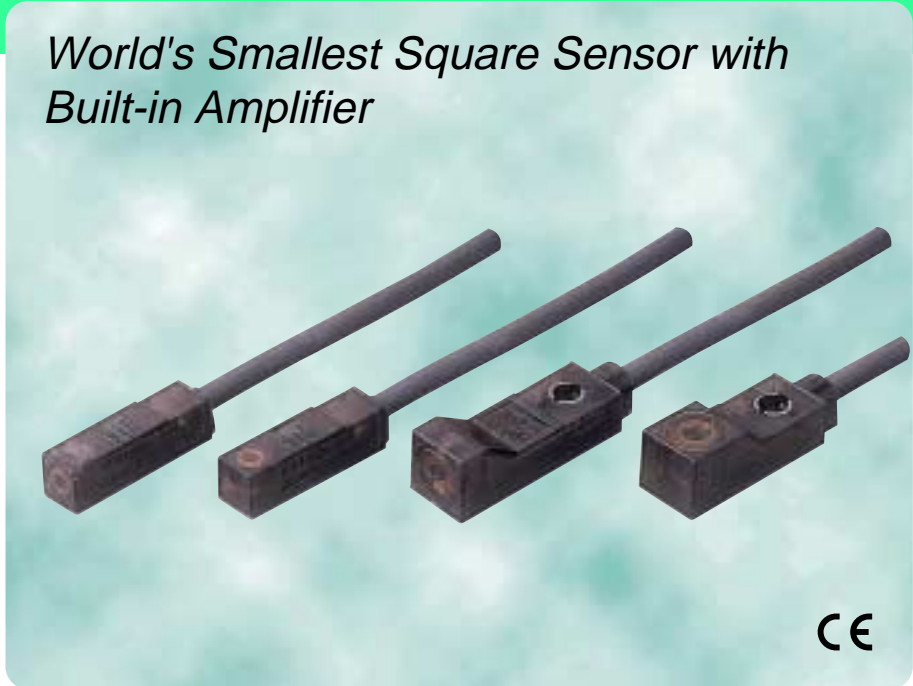

## Features

### **5.5 mm** World's Smallest Sensor with Built-in Amplifier

5.5 mm x 5.5 mm type contributes to smaller, space-saving machines and devices.

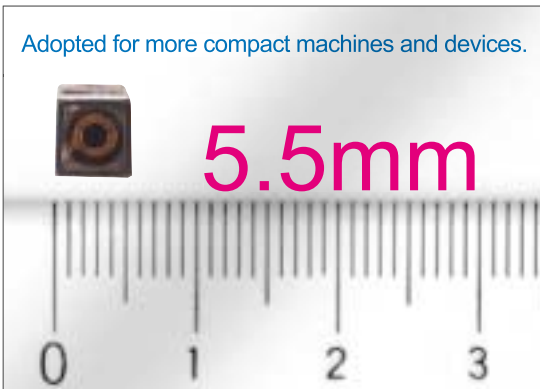

### **1 kHz** High-Speed Response

Achieves a 1 kHz response frequency matching increased machine and device speed.

### **IP67** Environmental Resistant Types

Full sealing structure housing, degree of protection IEC60529 IP67.

### **1.5 times** Long Sensing Distance (Compared to conventional models)

Long Sensing Distance: (E2S-□1, 1.6 mm) (E2S-□2, 2.5 mm)

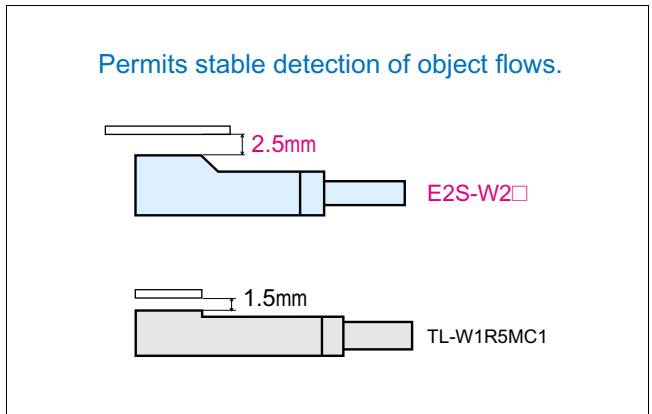

### **1/20** Low Current Consumption (Compared to conventional models)

Significantly lower current consumption. The 0.8 mA (for 24 VDC) leak current for the DC 2-wire type is approximately 1/20 that of the conventional DC 3-wire type. Optimal for multiple-sensor applications such as cam switches.

## Ordering Information

### Sensors

#### DC 2-wire Models

Shape	Sensing surface	Sensing distance	Model	
			Operating status	
			NO	NC
 Unshielded	Front face	1.6mm	<b>E2S-W11</b> *	<b>E2S-W12</b>
	End face		<b>E2S-Q11</b> *	<b>E2S-Q12</b>
	Front face	2.5mm	<b>E2S-W21</b> *	<b>E2S-W22</b>
	End face		<b>E2S-Q21</b> *	<b>E2S-Q22</b>

\* Models with different in response frequency are available (NO only). These model numbers take the form of E2S-□□□B (e.g., E2S-W11B)





#### DC 3-wire Models

Shape	Sensing surface	Sensing distance	Output specifications	Model		
				Operating status		
				NO	NC	
 Unshielded	Front face	1.6mm	NPN	<b>E2S-W13</b> *	<b>E2S-W14</b>	
	End face			<b>E2S-Q13</b> *	<b>E2S-Q14</b>	
	Front face	2.5mm		<b>E2S-W23</b> *	<b>E2S-W24</b>	
	End face			<b>E2S-Q23</b> *	<b>E2S-Q24</b>	
	Front face	1.6mm	PNP	<b>LE2S-W15</b> *	<b>E2S-W16</b>	
	End face			<b>4E2S-Q15</b> *	<b>E2S-Q16</b>	
	Front face			2.5mm	<b>E2S-W25</b> *	<b>E2S-W26</b>
	End face				<b>E2S-Q25</b> *	<b>E2S-Q26</b>

\* Models with different in response frequency are available (NO only). These model numbers take the form of E2S-□□□B (e.g., E2S-W11B)

### Accessories (Order Separately)

#### Mounting Brackets

Shape	Model	Quantity	Remarks
	<b>Y92E-C1R6</b>	1	Provided with 2S-
	<b>Y92E-C2R5</b>		Provided with E2S-□2□□
	<b>Y92E-D1R6</b>		---
	<b>Y92E-D2R5</b>		---

## Nomenclature

E2S - □ □ □ □

① ② ③ ④ ⑤

① Compact square series

② Sensing direction  
W: Front face sensing  
Q: End face sensing

③ Size and sensing distance (standard sensing object)  
1: 5.5 x 5.5 mm, 1.6 mm (iron)  
2: 8 x 8 mm, 2.5 mm (iron)

④ Output  
1: DC 2-wire NO  
2: DC 2-wire NC  
3: DC 3-wire NPN NO  
4: DC 3-wire NPN NC  
5: DC 3-wire PNP NO  
6: DC 3-wire PNP NC

⑤ Different response frequency  
No: Standard  
B: Different response frequency

## Rating/performance

### DC 2-wire Models

Item	Model	E2S-W11 E2S-W12	E2S-Q11 E2S-Q12	E2S-W21 E2S-W22	E2S-Q21 E2S-Q22
Sensing surface		Front face	End face	Front face	End face
Sensing distance		1.6 mm ±10%		2.5 mm ±15%	
Setting distance		0 to 1.2 mm		0 to 1.9 mm	
Differential distance		10% max.			
Sensing object		Ferrous metal (Sensitivity lowers with non-ferrous metals)			
Standard sensing object		Iron, 12 × 12 × 1 mm		Iron, 15 × 15 × 1 mm	
Response frequency		1 kHz min.			
Rated supply voltage (operating voltage)		12 to 24 VDC (10 to 30 VDC), ripple (p-p): 10% max.			
Leakage current		0.8 mA max.			
Control output	Switching capacity	3 to 50 mA DC max.			
	Residual voltage	3 V max. (under load current of 50 mA with cable length of 1 m)			
Indicator lamp		<input type="checkbox"/> <input type="checkbox"/> 1 models: Operation indicator (red LED), Operation set indicator (green LED) <input type="checkbox"/> <input type="checkbox"/> 2 models: Operation indicator (red LED)			
Operating status (with sensing object approaching)		<input type="checkbox"/> <input type="checkbox"/> 1 models: NO <input type="checkbox"/> <input type="checkbox"/> 2 models: NC			

\* The response frequencies for DC switching are average values measured on condition that the distance between each sensing object is twice as large as the size of the sensing object and the sensing distance set is half of the maximum sensing distance.

### DC 3-wire Models

Item	Model	E2S-W13 E2S-W14	E2S-Q13 E2S-Q14	E2S-W23 E2S-W24	E2S-Q23 E2S-Q24	E2S-W15 E2S-W16	E2S-Q15 E2S-Q16	E2S-W25 E2S-W26	E2S-Q25 E2S-Q26
Sensing surface		Front face	End face	Front face	End face	Front face	End face	Front face	End face
Sensing distance		1.6 mm ±10%		2.5 mm ±15%		1.6 mm ±10%		2.5 mm ±15%	
Setting distance		0 to 1.2 mm		0 to 1.9 mm		0 to 1.2 mm		0 to 1.9 mm	
Differential distance		10% max.							
Sensing object		Ferrous metal							
Standard sensing object		Iron, 12 × 12 × 1 mm		Iron, 15 × 15 × 1 mm		Iron, 12 × 12 × 1 mm		Iron, 15 × 15 × 1 mm	
Response frequency		1 kHz min.							
Rated supply voltage (operating voltage)		12 to 24 VDC (10 to 30 VDC), ripple (p-p): 10% max.							
Current consumption		13 mA max. (24 VDC, unload)							
Control output	Switching capacity	NPN open collector 100 mA max. (30 VDC max.)				PNP open collector 50 mA max. (30 VDC max.)			
	Residual voltage	1 V max. (under load current of 50 mA with cable length of 1 m)							
Indicator lamp		Operation indicator (orange)							
Operating status (with sensing object approaching)		<input type="checkbox"/> <input type="checkbox"/> 3 models: NO <input type="checkbox"/> <input type="checkbox"/> 4 models: NC				<input type="checkbox"/> <input type="checkbox"/> 5 models: NO <input type="checkbox"/> <input type="checkbox"/> 6 models: NC			

\* The response frequencies for DC switching are average values measured on condition that the distance between each sensing object is twice as large as the size of the sensing object and the sensing distance set is half of the maximum sensing distance.

## Specifications

Item	Model	E2S-□□□
Protective circuits	Reverse polarity connection and surge absorber	
Ambient temperature	Operating: -25°C to 70°C, Storage: -40°C to 85°C (with no icing or condensation)	
Ambient humidity	Operating: 35% to 90%RH, Storage: 35% to 95%RH (with no condensation)	
Temperature influence	±15% max. of sensing distance at 23°C in temperature range of -25°C to 70°C	
Voltage influence	±2.5% max. of sensing distance within a range of ±10% of rated power supply voltage	
Insulation resistance	50 MΩ min. (at 500 VDC) between current carry parts and case	
Dielectric strength	1,000 VAC for 1 min between current carry parts and case	
Vibration resistance	10 to 55 Hz, 1.5-mm double amplitude for 2 hours each in X, Y, and Z directions	
Shock resistance	Destruction: 500 m/s <sup>2</sup> for 3 times each in X, Y, and Z directions	
Protective structure	IEC60529 IP67	
Connection method	Pre-wired models (Standard length: 3 m)	
Weight (Packed state)	Approx. 10 g	
Material	Case	Polyarylate
Accessories	Mounting Brackets	

## Characteristic data (typical)

### Sensing Distance vs. Sensing Object

E2S-W1□/-Q1□

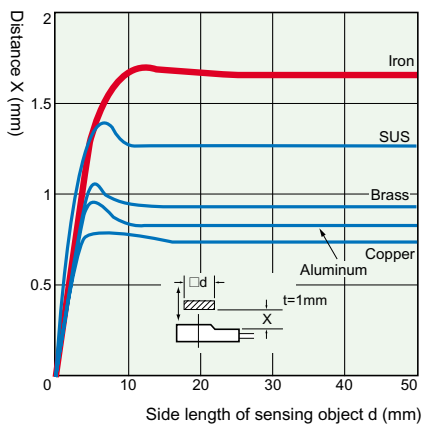

E2S-W2□/-Q2□

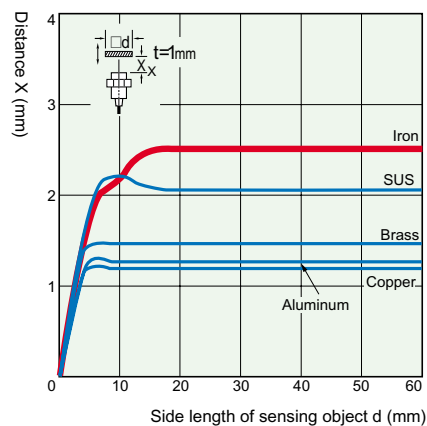

# Output Circuit Diagram

## DC 2-wire Models

Operating status	Model	Timing chart	Output circuit
NO	E2S-W11 E2S-W21 E2S-Q11 E2S-Q21	<p>Setting position</p> <p>Non-sensing zone    Unstable Sensing zone    Stable sensing zone</p> <p>Sensing object</p> <p>(%)    100    80    0</p> <p>Rated sensing distance</p> <p>ON    OFF    ON    OFF    ON    OFF</p> <p>Setting indicator (green)</p> <p>ON    OFF    ON    OFF    ON    OFF</p> <p>Operation indicator (red)</p> <p>ON    OFF    ON    OFF    ON    OFF</p> <p>Control output</p>	<p>Main circuit</p> <p>Brown Load +V</p> <p>Blue 0V</p>
NC	E2S-W12 E2S-W22 E2S-Q12 E2S-Q22	<p>Non-sensing zone    Sensing zone</p> <p>Sensing object</p> <p>(%)    100    0</p> <p>Non-sensing zone</p> <p>ON    OFF    ON    OFF</p> <p>Operation indicator (red)</p> <p>ON    OFF    ON    OFF</p> <p>Control output</p>	<p>Main circuit</p> <p>Brown Load +V</p> <p>Blue 0V</p>

## DC 3-wire Models

Operating status	Output specifications	Model	Timing chart	Output circuit
NO	NPN	E2S-W13 E2S-W23 E2S-Q13 E2S-Q23	<p>Sensing object    Yes    No</p> <p>Output transistor (load)    ON    OFF</p> <p>Operation indicator (orange)    ON    OFF</p>	<p>Main circuit</p> <p>Brown +V</p> <p>Black Output</p> <p>Blue 0V</p> <p>* Maximum load current: 50 mA</p>
NC		E2S-W14 E2S-W24 E2S-Q14 E2S-Q24	<p>Sensing object    Yes    No</p> <p>Output transistor (load)    ON    OFF</p> <p>Operation indicator (orange)    ON    OFF</p>	
NO	PNP	E2S-W15 E2S-W25 E2S-Q15 E2S-Q25	<p>Sensing object    Yes    No</p> <p>Output transistor (load)    ON    OFF</p> <p>Operation indicator (orange)    ON    OFF</p>	<p>Main circuit</p> <p>Brown +V</p> <p>Black Output</p> <p>Blue 0V</p> <p>* Maximum load current: 50 mA</p>
NC		E2S-W16 E2S-W26 E2S-Q16 E2S-Q26	<p>Sensing object    Yes    No</p> <p>Output transistor (load)    ON    OFF</p> <p>Operation indicator (orange)    ON    OFF</p>	

Precautions

Correct Use

Design

Effects of Surrounding Metal

Provide a minimum distance as shown in the table below between the Sensor and the surrounding metal.

Front Surface Sensing Type (Not Exceeding The Height of The Sensor Head)

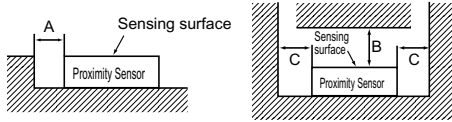

(Unit: mm)

Model	Length	A	B	C
E2S-W1□		0	8	2
E2S-W2□			15	10

End Surface Sensing Type

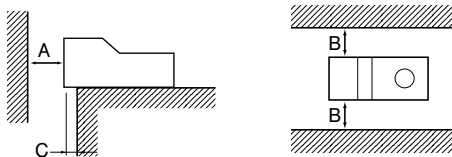

(Unit: mm)

Model	Length	A	B	C
E2S-Q1□		8	3	2
E2S-Q2□		15	10	3

Mutual Interference

If more than one Sensor is located face-to-face or in parallel, be sure to maintain enough space, as provided in the following diagram, between adjacent Sensors to suppress mutual interference.

Front Surface Sensing Type End Surface Sensing Type

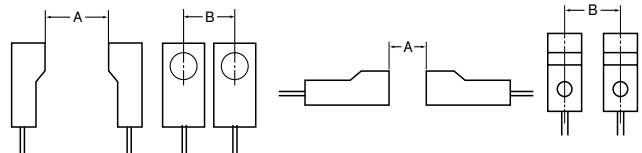

(Unit: mm)

Model	Length	A	B
E2S-W(Q)1□		50 (40)	20 (5.5)
E2S-W1□		75 (50)	25 (8)

Note: The above values in parentheses are applicable when using two sensors with different frequencies.

Mounting

Tightening torques

Do not tighten the E2S-W(Q)2□ mounting screws to a torque exceeding 0.7 N•m.

Dimensions (Unit: mm)

Sensors

E2S-W1□

CAD file E2S\_03

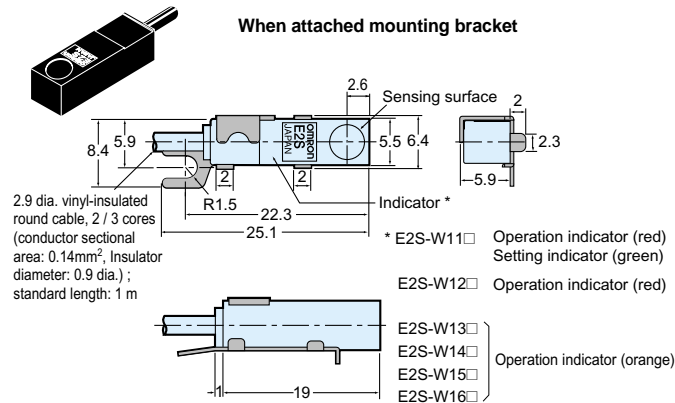

E2S-Q1□

CAD file E2S\_04

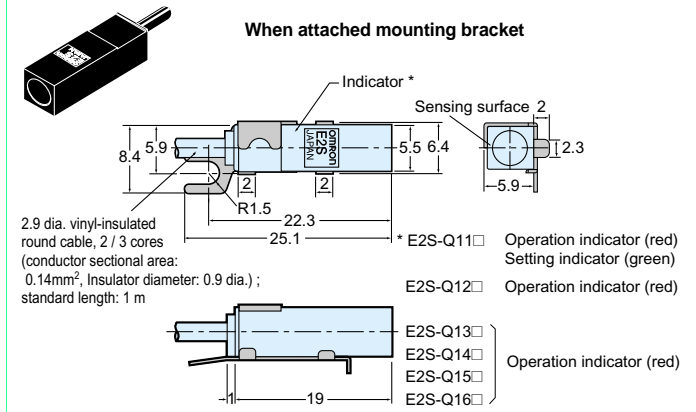

E2S-W2□

CAD file E2S\_02

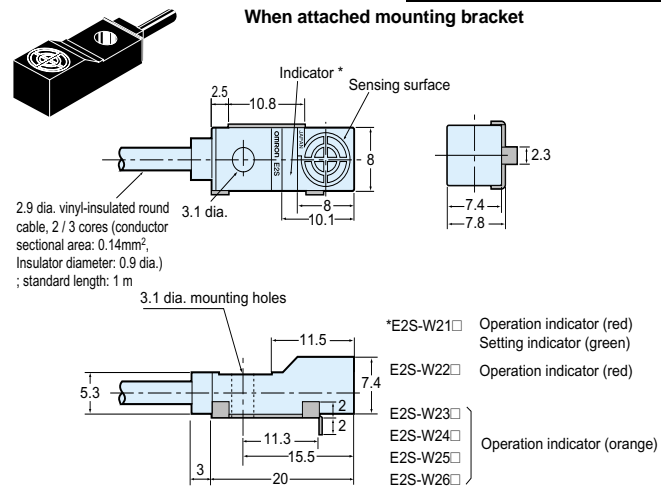

E2S-Q2□

CAD file E2S\_01

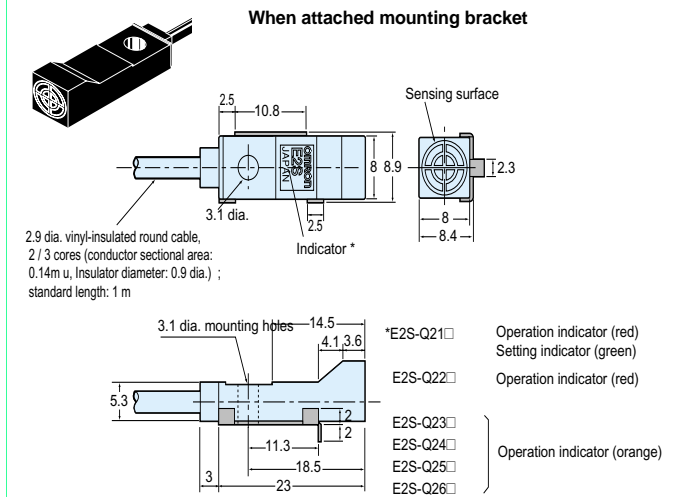

Accessories (Order Separately)

Mounting Brackets

Y92E-C1R6

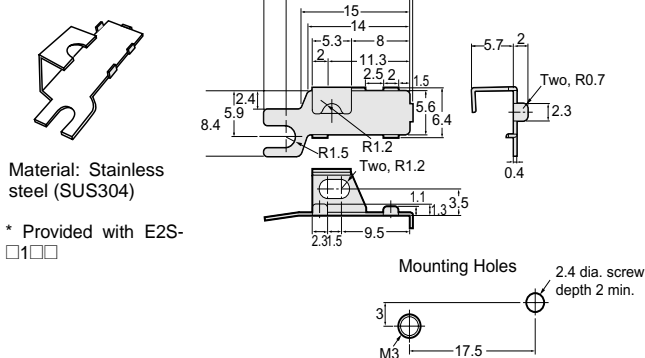

Mounting Brackets

Y92E-C2R5

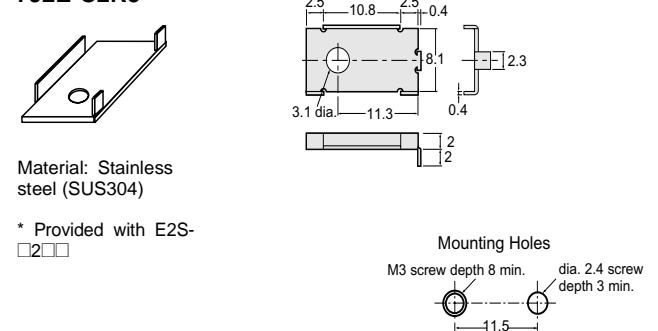

Mounting Brackets

Y92E-D1R6

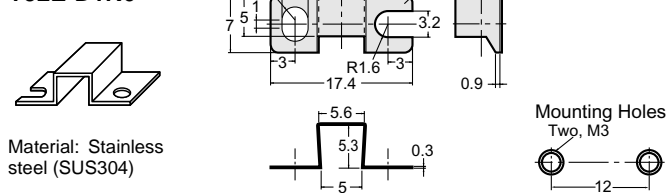

Mounting Brackets

Y92E-D2R5

