

Teaching Proximity Sensor (Separate Amplifier Type)

E2C-T

Proximity Sensor with Separate Amplifier Unit and Teaching Function for Precise Sensitivity Adjustment



Features

Three teaching modes allow easy setup

Three types of teaching (i.e., teaching with and without a sensing object, teaching without sensing object, and positioning teaching) ensure easy sensitivity adjustment.

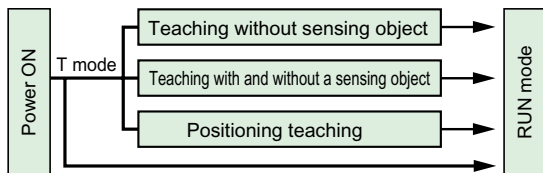

10-mm-wide, slim Amplifier Unit.

The width of amplifier is 10mm (14mm of conventional models), and it contributes to space saving. The E2C-T16 is a new product that incorporates a connector and connects to the Sensor Terminals for CompoBus/S use.



Can be used with many existing sensor

In addition to the pillar type of the conventional E2C sensor heads M8, 5.4 dia., M5, 3.8 dia., and 3.5 dia., and the sensor head of 2 dia. is also lineup. A sensor cord can be cut into the optimal length.

(Except E2C-CR5B2)



Application

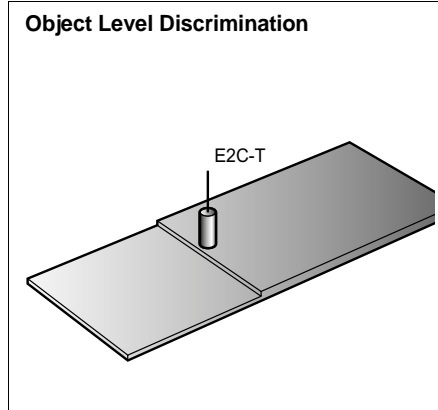
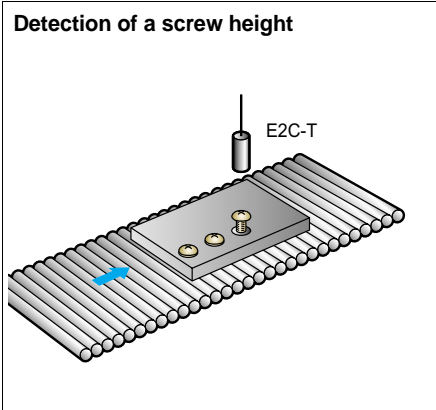

Ordering Information

Sensors

Sensors

Shape		Stable sensing range (within whole rated temperature range)	Stable sensing range 0°C to 40°C	Model
Non-shielded *	2.0-mm dia.	0.5mm	0.7mm	E2C-CR5B2
Shielded	3.5-mm dia.	0.8mm	1.2mm	E2C-CR8A
	3.8-mm dia.	0.8mm	1.2mm	E2C-CR8B
	M5	1mm	1.5mm	E2C-X1A
	5.4-mm dia.	1mm	1.5mm	E2C-C1A
	M8	1.5mm	2mm	E2C-X1R5A

Amplifier Units

Model
E2C-T11

* Although the E2C-CR5B2 is a shielded construction, this model cannot be embedded in metal.

Note: Sensors other than the following cannot be used.

Accessories (Order Separately)

Mounting Brackets

Model	Applicable models
Y92E-B8	E2C-X1R5A
Y92E-F3R5	E2C-CR8A
Y92E-F5R4	E2C-C1A

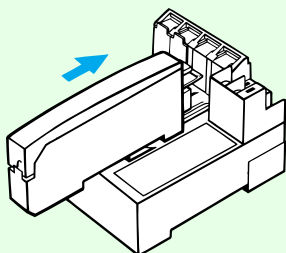

CompoBus/S

The E2C-T16 is a new product that incorporates a connector and connects to the Sensor Terminals for CompoBus/S use.

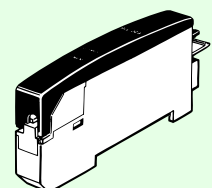

Refer to CompoBus/S (catalog No.: SCEJ-002) for details.

Rating/performance

Sensors

Item	Model	E2C-CR5B2	E2C-CR8A E2C-CR8B	E2C-X1A E2C-C1A	E2C-X1R5A
Stable sensing range (within whole rated temperature range)		0 to 0.5 mm	0 to 0.8 mm	0 to 1 mm	0 to 1.5 mm
Stable sensing range at 0°C to 40°C		0 to 0.7 mm	0 to 1.2 mm	0 to 1.5 mm	0 to 2 mm
Sensing object		Ferrous metal (Sensitivity lowers with non-ferrous metals)			
Standard sensing object		Iron, 5 × 5 × 1 mm			Iron, 8 × 8 × 1 mm
Response frequency*1		1 kHz			800 Hz
Ambient temperature	Operating/Storage:	-10°C to 55°C			
	(with no icing or condensation)	Operating: -25°C to 70°C			
Ambient humidity		Operating/Storage: 35% to 95%RH (with no condensation)			
Temperature influence	±25% max. of sensing distance at 23°C in the temperature range of -10°C to 55°C	±15% max. of sensing distance at 23°C in temperature range of -25°C to 70°C			
Vibration resistance		10 to 55 Hz, 1.5-mm double amplitude for 2 hours each in X, Y, and Z directions			
Shock resistance		Destruction: 500 m/s ² for 3 times each in X, Y, and Z directions			
Protective structure		IEC60529 IP64	IEC60529 IP67		
Connection method		Pre-wired models (shielded cable: 3 m only)	Pre-wired models (high frequency coaxial cable; standard length: 2 m) *2		
Weight (Packed state)		Approx. 10 g	Approx. 40g	Approx. 45 g	Approx. 50 g
	Material	Case	Stainless steel		Brass
		Sensing surface	ABS		
		Cable	Polyethylene		

*1. The response frequencies measured on condition that the distance between each sensing object is twice as large as the size of the sensing object and the sensing distance set is half of the maximum sensing distance.

*2. The characteristic impedance of the coaxial cable for high-frequency use is 50 Ω.

Amplifier Units

Item	Model	E2C-CR5B2	E2C-CR8A/CR8B	E2C-X1A/C1A	E2C-X1R5A	
Rated supply voltage (operating voltage)		12 to 24 VDC ±10% with a ripple (p-p) of 10% max.				
Current consumption		50 mA max.				
Sensing distance adjustment range*1	Setting distance for teaching without sensing object	0.4 mm min.	0.72 mm min.	0.9 mm min.	0.35 mm min.	
	Setting distance for teaching with and without sensing object or positioning teaching	0°C to 40°C	0.1 to 0.7 mm	0.16 to 1.2 mm	0.2 to 1.5 mm	0.3 to 2 mm
		0°C to 55°C	0.1 to 0.5 mm	0.16 to 0.8 mm	0.2 to 1.0 mm	0.3 to 1.5 mm
Differential distance		15% max. of sensing distance	10% max.			
Response time		Refer to the response frequency of the Proximity Sensor in use.				
Control output		NPN open collector 100 mA max. (under 30 VDC) (residual voltage 1 V max.)				
Operating status		NO/NC selectable				
Indicator lamp		Operation indicator (orange) and stability indicator (green)				
Cord length compensation		3 m only	1, 2, or 3 m selectable			
Ambient temperature		Operating/Storage: 0°C to 55°C (with no icing or condensation)				
Ambient humidity		Operating/Storage: 35% to 95%RH (with no condensation)				
Temperature influence	±25% max. of sensing distance at 23°C in the temperature range of 0°C to 55°C	±10% max. of sensing distance at 23°C in the temperature range of 0°C to 55°C				
Voltage influence		1% max. of sensing distance within a range of 90% to 110% of the rated power supply voltage.				
Insulation resistance		50 MΩ min. (at 500 VDC) between current carry parts and case				
Dielectric strength		1000 VAC 50/60 Hz for 1 min between current carrying part and case				
Vibration resistance		Destruction: 10 to 55 Hz, 1.5-mm double amplitude for 2 hours each in X, Y, and Z directions				
Shock resistance		Destruction: 500 m/s ² for 10 times each in X, Y, and Z directions				
Protective structure		IEC 60529 IP50				
Connection method		Pre-wired type (Standard length: 3 m)				
Weight (Packed state)		Approx. 70 g				
Accessories		Mounting bracket, instruction manual				

*1. Perform positioning teaching within the stable sensing distance, otherwise reset failures may result when the E2C-T is in operation. If a fine-difference teaching is performed with and without a sensing object, reset failures may result when the E2C-T is in operation even if teaching is successful.

Characteristic data (typical)

Sensing Distance vs. Sensing Object

E2C-CR5B2

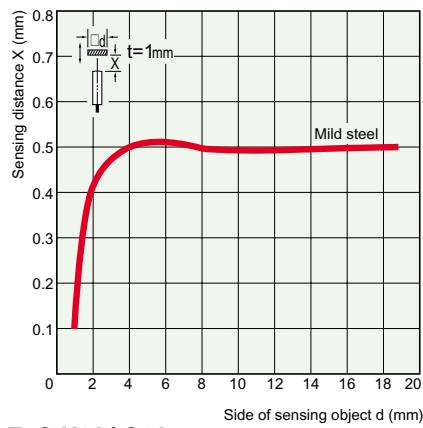

E2C-CR8□

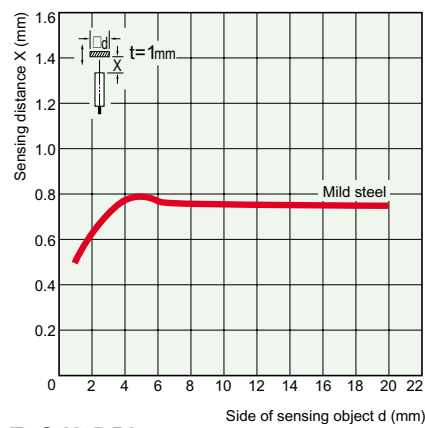

E2C-X1A/C1A

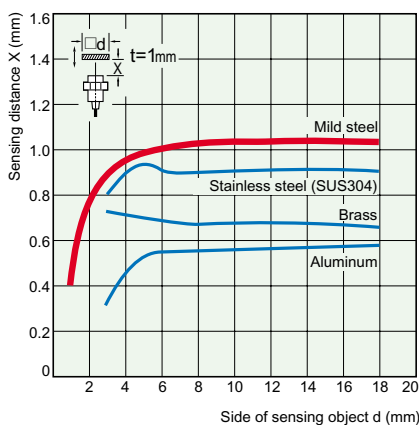

E2C-X1R5A

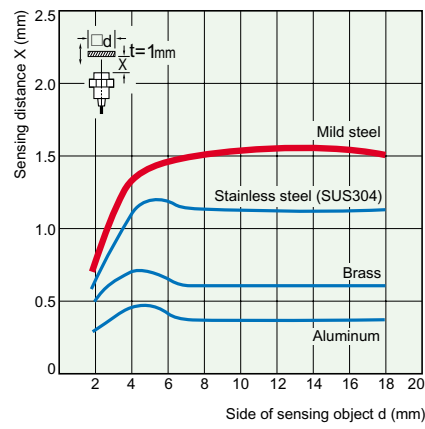

Output Circuit Diagram

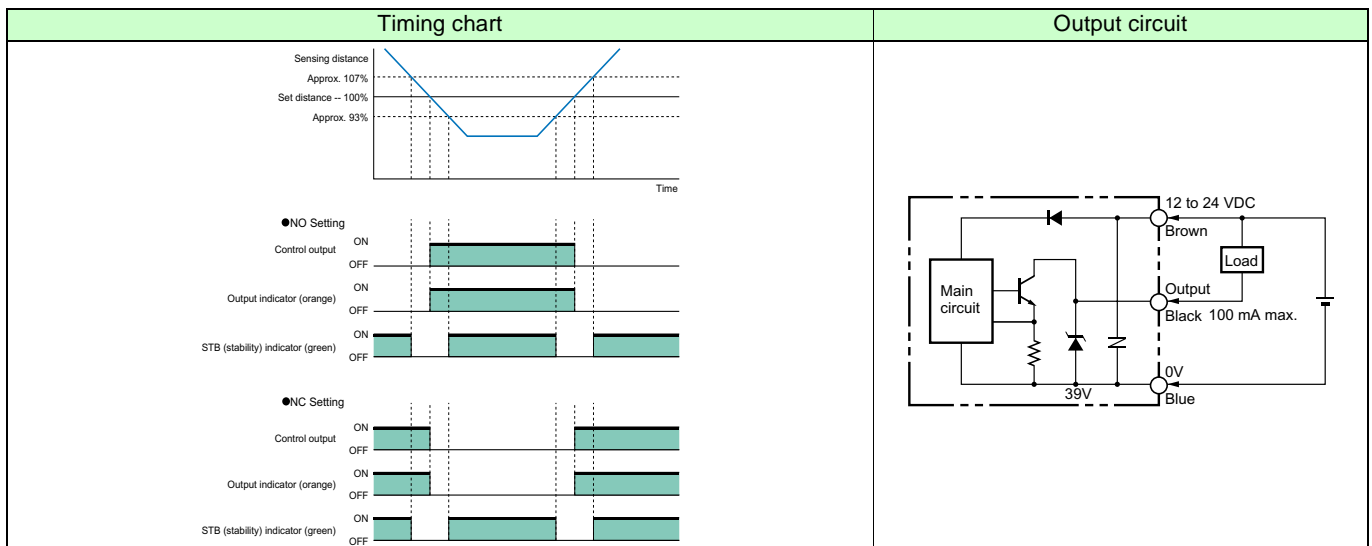

Connection

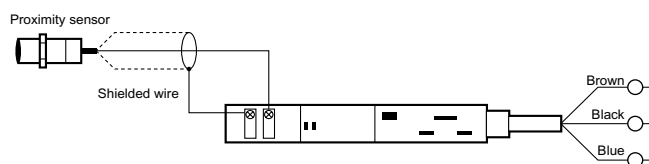

Display

The OUT indicator indicates the status of the control output transistor. The indicator will be ON when the transistor has control output (I.e., NPN open collector output).

If the operation selector is set to NO, the indicator will be ON when the sensing object is in the sensing distance range. If the operation selector is set to NC, the indicator will be ON when the sensing object is not in the sensing distance range. The STB (stability) indicator indicates the excess gain of object detection or non-detection. The indicator will be ON when the sensing object is within approximately 93% of the maximum sensing distance or at approximately 107% of the minimum sensing distance or beyond.

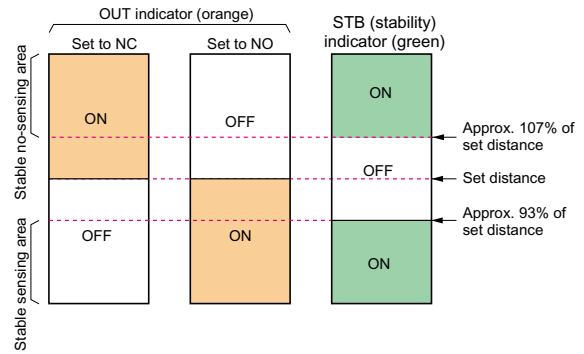

Nomenclature:

Amplifier Units

Switches and Functions

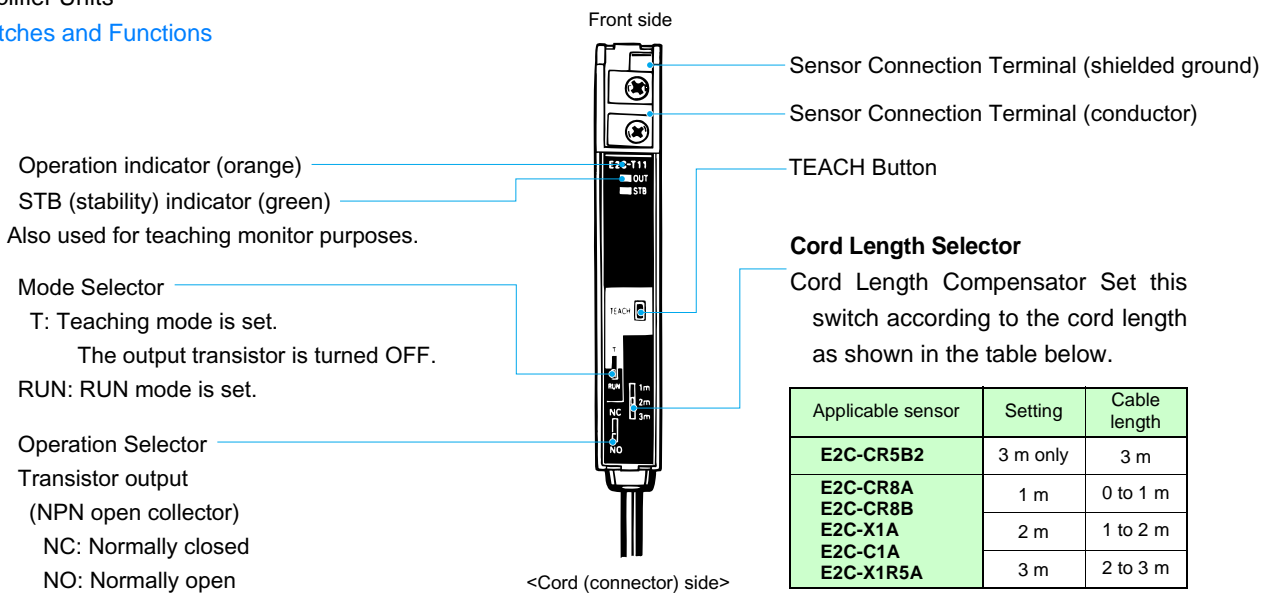

Applicable sensor	Setting	Cable length
E2C-CR5B2	3 m only	3 m
E2C-CR8A E2C-CR8B	1 m	0 to 1 m
	2 m	1 to 2 m
E2C-C1A E2C-X1R5A	3 m	2 to 3 m

Operation

Teaching Proximity Sensor with Separate Amplifier

The E2C-T is used for object detection, level difference detection, and positioning, and the sensitivity of the EC-T must be set according to the application. The following description provides information on the automatic teaching or the E2C-T for sensitivity adjustment.

Teaching with no sensing object

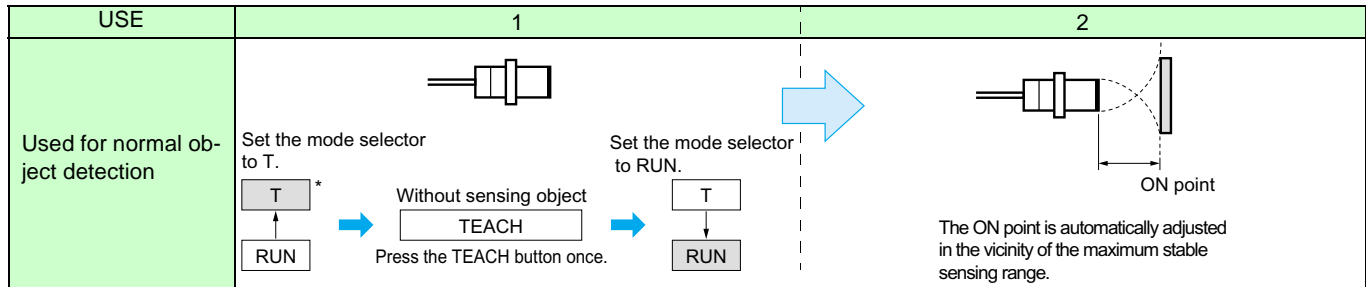

* No transistor output will be ON if the mode selector is set to , in which case a wrong signal may be output. The utmost attention is required for positioning teaching.

Note: 1. Refer to "Sensitivity Setting (automatical)" in detail on next page for further information.
2. Be sure to perform the teaching of the E2C-T before use.

Teaching with and without sensing object

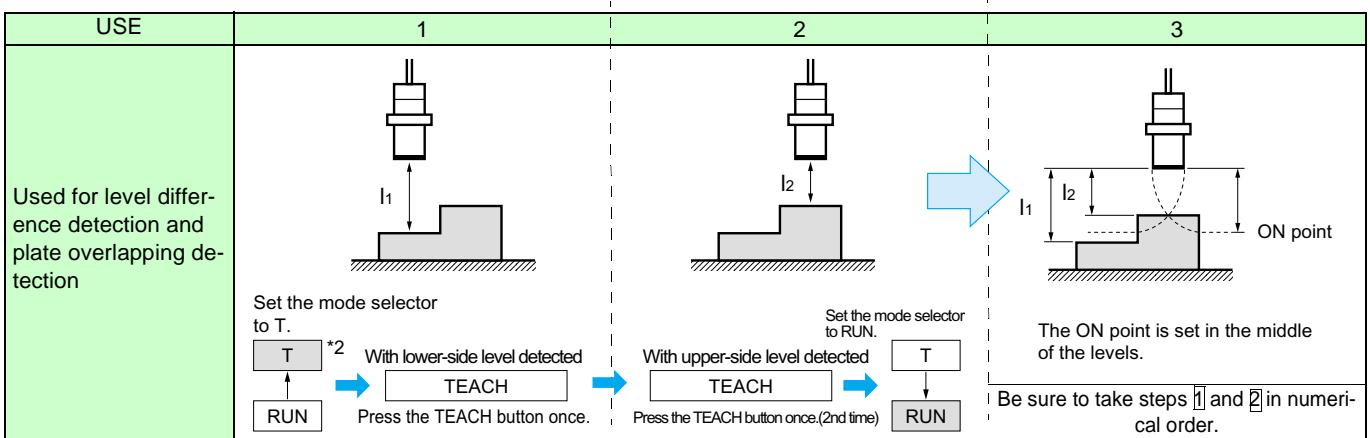

*1. If fine-difference teaching is performed, reset failures may result when the E2C-T is in operation even if the teaching is successful. Make sure that the E2C-T resets smoothly after the teaching.

*2. No transistor output will be ON if the mode selector is set to , in which case a wrong signal may be output. The utmost attention is required for positioning teaching.

Positioning teaching

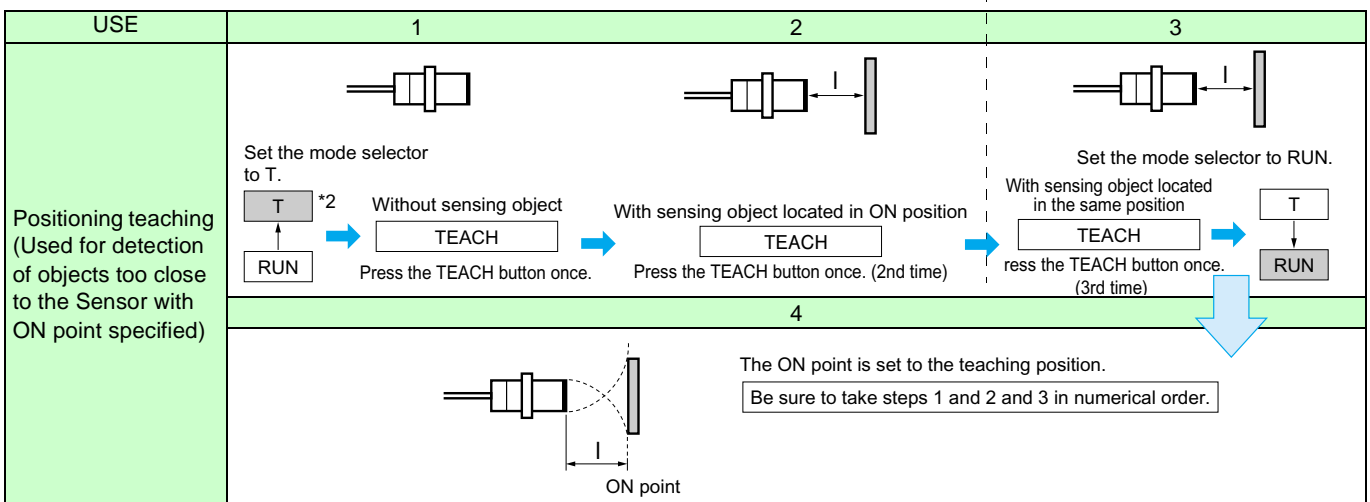

*1. Be sure to perform positioning teaching within the stable sensing distance range, otherwise reset failures may result even if teaching is successful. Be sure to check that the E2C-T can be reset after teaching. Refer to Ratings for the stability sensing range.

*2. No transistor output will be ON if the mode selector is set to , in which case a wrong signal may be output. The utmost attention is required for positioning teaching.

Sensitivity Setting (Automatic Teaching) in Detail

Teaching without sensing object

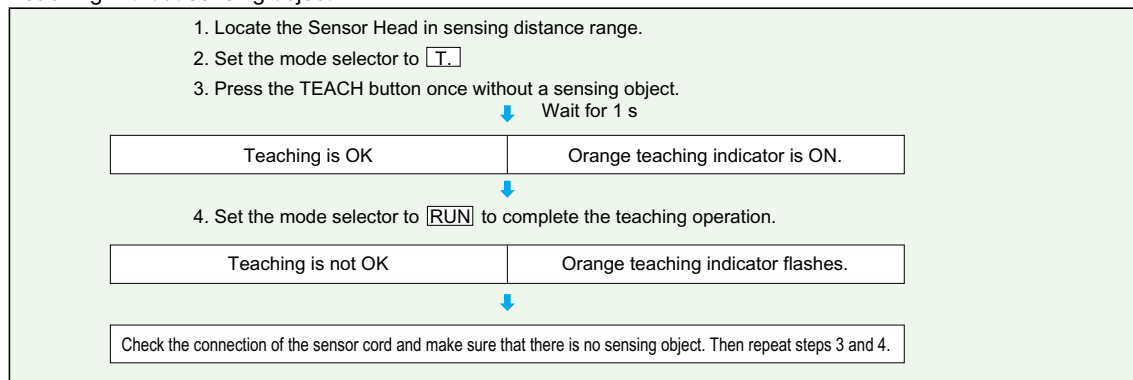

Teaching with and without a sensing object

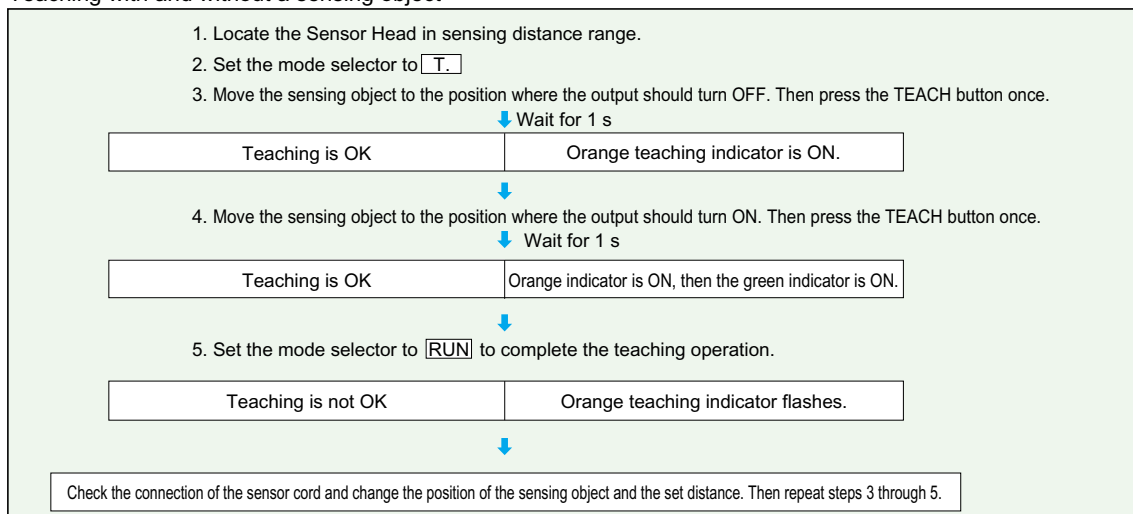

Positioning teaching

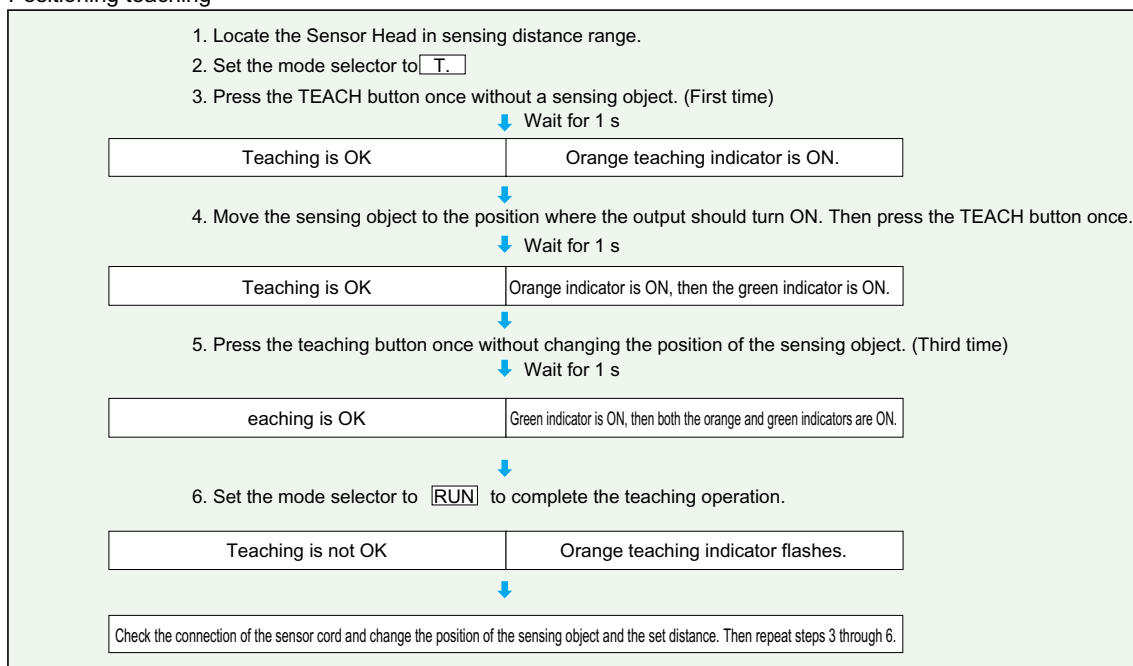

Note: Be sure to perform the teaching of the E2C-T before use.

Once the teaching of the E2C-T is performed, the teaching data set in the E2C-T will be retained even after turning OFF the E2C-T.

Precautions

Correct Use

Design

Effects of Surrounding Metal

Provide a minimum distance as shown in the table below between the Sensor and the surrounding metal.

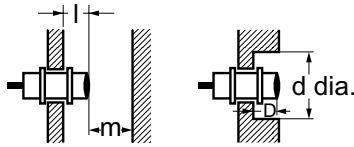

Effects of Surrounding Metal (Unit: mm)

Model	Distance	l	d	D	m
E2C-CR5B2	2	6 *	2	1.5	
E2C-CR8□	0	3.5	0	2.4	
E2C-X1A		5		3	
E2C-C1A		5.4			
E2C-X1R5A		8		4.5	

* Although the E2C-CR5B2 is a shielded construction, this model cannot be embedded in metal.

Mutual Interference

If more than one Sensor is located face-to-face or in parallel, be sure to maintain enough space, as provided in the following diagram, between adjacent Sensors to suppress mutual interference.

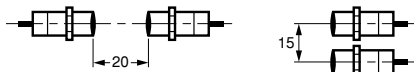

The mutual interference of the Sensors can be prevented by cord length selector settings which, however, also change the coil characteristics of the Sensors. As a result, the specified ratings may not be satisfied in all permissible temperature or sensing distance ranges. Test the operation of the Sensors before using them in actual operation. The locations of the Sensors shown below are not applicable to the E2C-CR5B2.

Mounting

Do not tighten the nut of the E2C-□ excessively. Be sure to tighten the nut with a toothed washer to the following torque.

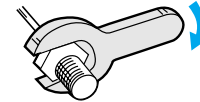

Model	Tensile strength (torque)
E2C-X1A	0.98 N•m
E2C-X1R5A	2 N•m

Note: Apply above tightening torque to each nut tightened with a toothed washer.

If a set screw is used for mounting a screwless, column model, make sure that the tightening torque does not exceed 0.2 N•m (2 kgf•cm).

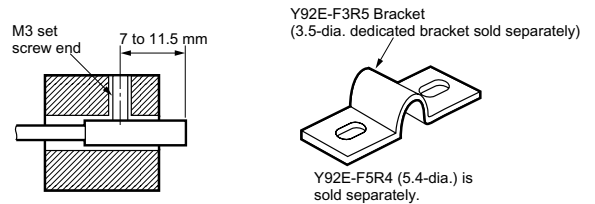

Processing the Sensor Cable Ends

The Amplifier Unit is of slim construction. Therefore, the end of the sensor cord connected to the E2C-□ must be processed as shown in the following illustration.

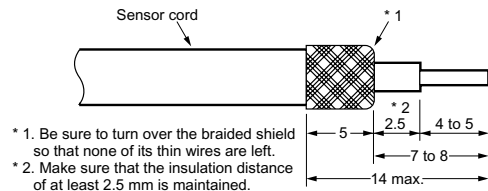

- * 1. Be sure to turn over the braided shield so that none of its thin wires are left.
- * 2. Make sure that the insulation distance of at least 2.5 mm is maintained.

Dimensions (Unit: mm)

Sensors
Amplifier

E2C-T11

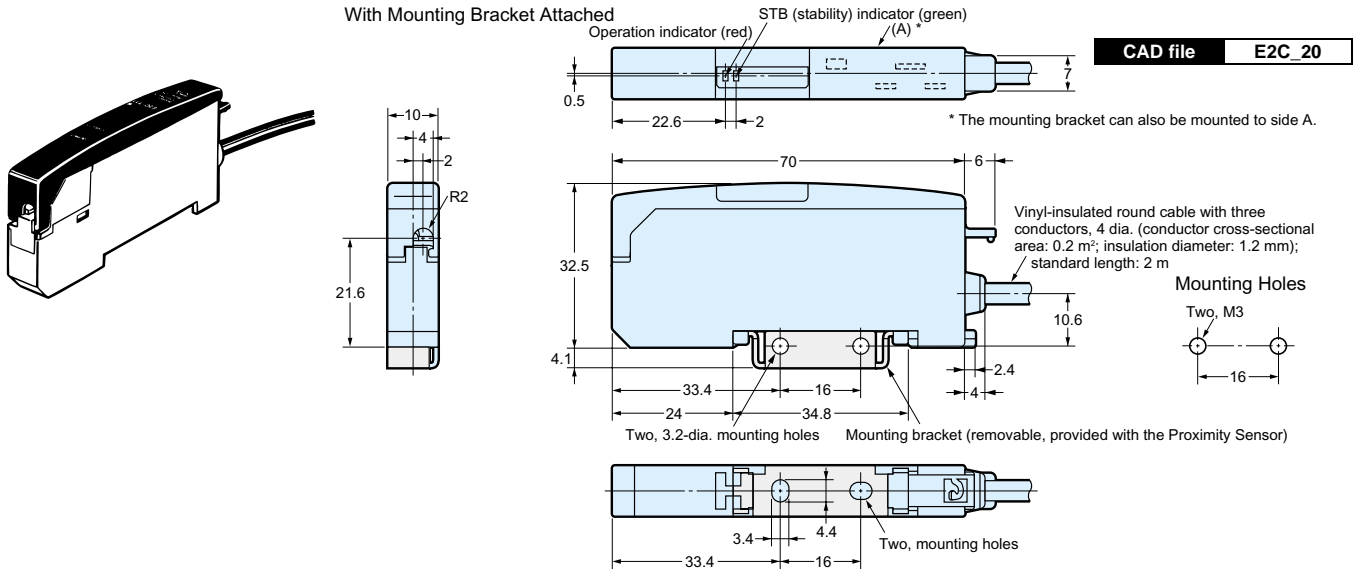

Sensors

E2C-CR5B2

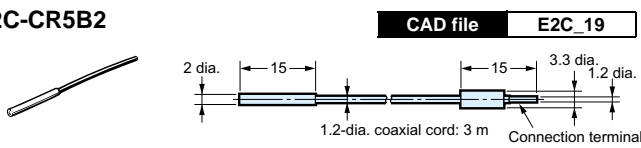

E2C-CR8A
E2C-CR8B

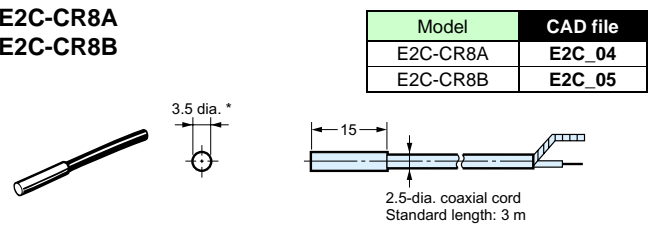

E2C-X1A

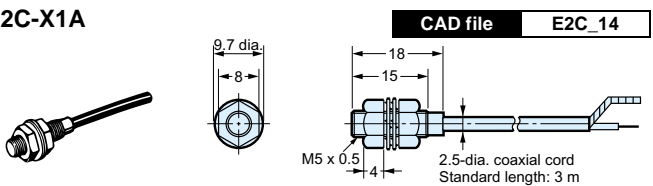

E2C-C1A

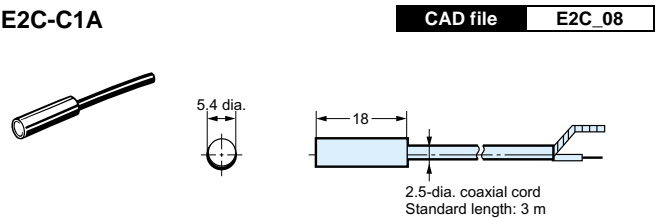

E2C-X1R5A

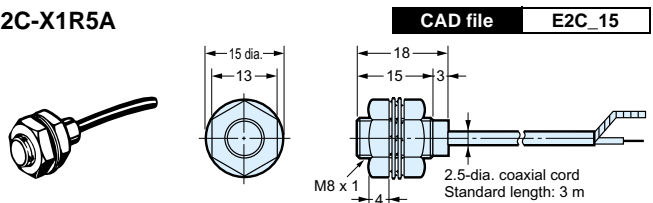

Accessories (Order Separately)

Mounting Brackets

Y92E-B8

