

## "Mini" Photoelectric Sensor

## E3T





**High cost-performance "Mini" Photoelectric Sensor Saves Installation Space and Wiring Effort and Detects Minute Sensing Objects**

- "Pin-point" beam (1 to 2-mm dia.) makes it possible to detect minute sensing objects.
- Saves wiring effort, even with compact body. Work steps can be reduced to half with the retroreflective or limited reflective model.
- Easy-to-use with a clearly-visible "Pin-point" beam.
- Long sensing distance of 1 meter is possible with the through-beam model.



## Ordering Information

### ■ Photoelectric Sensors

Item			Sensing method					
			Through-beam		Retroreflective	Diffuse reflective	Limited reflective	
<b>Appearance</b>			Side-view 	Flat 	Side-view 	Flat 	Side-view 	
<b>Sensing distance</b>			1 m	500 mm	200 mm (10 mm) (see note)	5 to 30 mm	5 to 15 mm	5 to 30 mm
<b>Model</b>	<b>Light-ON</b>	NPN	E3T-ST11	E3T-FT11	E3T-SR11	E3T-FD11	E3T-SL11	E3T-SL21
		PNP	E3T-ST13	E3T-FT13	E3T-SR13	E3T-FD13	E3T-SL13	E3T-SL23
	<b>Dark-ON</b>	NPN	E3T-ST12	E3T-FT12	E3T-SR12	E3T-FD12	E3T-SL12	E3T-SL22
		PNP	E3T-ST14	E3T-FT14	E3T-SR14	E3T-FD14	E3T-SL14	E3T-SL24

**Note:** Set the distance between the Sensor and Reflector to a value larger than the one indicated in parentheses.

### ■ Accessories (Order Separately)

#### Slits

For E3T-ST1j

Slit width	Sensing distance (typical)	Minimum sensing object (typical)	Model	Remarks
0.5 dia.	100 mm	0.5 dia.	E39-S63	One each for Emitter and Receiver; common with Slit widths of 1 dia. and 0.5 dia.
1 dia.	300 mm	1 dia.		

For E3T-FT1j

Slit width	Sensing distance	Minimum sensing object (typical)	Model	Remarks
0.5 dia.	50 mm	0.5 dia.	E39-S64	One each for Emitter and Receiver; common with Slit widths of 1 dia. and 0.5 dia.
1 dia.	100 mm	1 dia.		

Reflectors

Name	Sensing distance	Minimum sensing object (typical)	Model
For retroreflective model	200 mm (10 mm) (rated value) (see note 2)	2 dia.	E39-R4 (see note 1)
	100 mm (10 mm) (see note 2)		E39-R37





Note: 1. Attached to the E3T-SR1j retroreflective model.  
 2. Set the distance between the Sensor and Reflector to a value larger than the one indicated in parentheses.

Sensitivity Adjustment Unit

For E3T-ST1j

Appearance	Sensing distance (typical)	Model
	300 to 800 mm	E39-E10

Mounting Brackets

Model	Appearance	Applied model	Remarks
E39-L116		Common with the E3T-Sj .	Two mounting brackets are required for through-beam models.
E39-L117			
E39-L118			
E39-L119		Common with the E3T-Fj .	
E39-L120			

Application Examples

Detection of Lead Frame Rise (Pressure Machines)

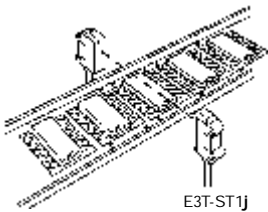

Checking of IC Set (Handler)

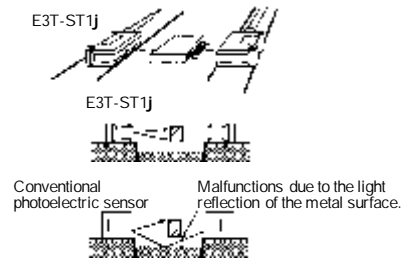

Detection of IC Chips on Tape (Taping Machines)

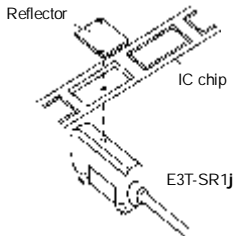

Detection of Cassette or Magazine on the Conveyor

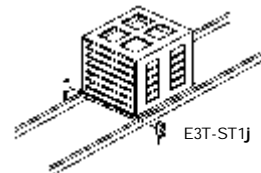

# Specifications

## ■ Ratings/Characteristics

E3T-j j j j

Item	Through-beam				Retroreflective		Limited reflective				Diffuse reflective	
	Side-view		Flat				Side-view				Flat	
	NPN	PNP	NPN	PNP	NPN	PNP	NPN	PNP	NPN	PNP	NPN	PNP
Light-ON	-ST11	-ST13	-FT11	-FT13	-SR11	-SR13	-SL11	-SL13	-SL21	-SL23	-FD11	-FD13
Dark-ON	-ST12	-ST14	-FT12	-FT14	-SR12	-SR14	-SL12	-SL14	-SL22	-SL24	-FD12	-FD14
Sensing distance	1 m (Sensitivity Adjustment Unit is available)		500 mm		200 mm (10 mm) (see note) (with the E39-R4)		5 to 15 mm (50 x 50 mm white paper)		5 to 30 mm (50 x 50 mm white paper)		5 to 30 mm (50 x 50 mm white paper)	
Standard sensing object (white paper)	Opaque, 2 dia. min.				Opaque, 27 dia. min.		---					
Min. sensing object (typical)	Opaque, 2 dia. min.				2 dia. (sensing distance of 100 mm)		0.15 dia. (sensing distance of 10 mm)					
Differential travel	---						2 mm max.		6 mm max.		6 mm max.	
Directional angle	Emitter: 3° to 10° Receiver: 3 to 70°		Emitter: 3° to 13° Receiver: 3 to 70°		Emitter: 2° to 5°		---					
Light source (wave length)	Red LED ("Pin-point" LED) ( $\lambda=670$ nm)											
Power supply voltage	12 to 24 VDC $\pm 10\%$ , ripple (p-p) 10% max.											24 VDC $\pm 10\%$
Current consumption	Emitter/Receiver: 12 mA max.				20 mA max.							
Control output	Open collector, load current: 50 mA max. at 24 VDC, residual voltage: 1 V max., operation mode: Light ON or Dark ON (separate models)											
Circuit protection	Protection from reversed power supply connection and output short-circuit				Protection from reversed power supply connection, output short-circuit, and mutual interference							
Protection	Protection from reversed power supply connection and output short-circuit											
Response time	1 ms max. each for operation and release											
Ambient illumination (on Receiver lens)	Incandescent lamp: 5,000 lx max. Sunlight: 10,000 lx max.											
Ambient temperature	Operating: -25°C to 55°C Storage: -40°C to 70°C (with no icing or condensation)											
Ambient humidity	Operating: 35% to 85% Storage: 35% to 95% (with no condensation)											
Insulation resistance	20 M $\Omega$ min. (at 500 VDC)											
Dielectric strength	1,000 VAC, 50/60 Hz for 1 min											
Vibration resistance	Destruction: 10 to 2,000 Hz, 1.5-mm double amplitude or 300 m/s <sup>2</sup> (approx. 30G) for 0.5 hrs each in X, Y, and Z directions											
Shock resistance	Destruction: 1,000 m/s <sup>2</sup> (approx. 100G) 3 times each in X, Y, and Z directions											
Degree of protection	IEC60529: IP67											
Connection method	Prewired (standard length: 2 m)											

Item	Through-beam				Retroreflective		Limited reflective				Diffuse reflective	
	Side-view		Flat				Side-view				Flat	
	NPN	PNP	NPN	PNP	NPN	PNP	NPN	PNP	NPN	PNP	NPN	PNP
Light-ON	-ST11	-ST13	-FT11	-FT13	-SR11	-SR13	-SL11	-SL13	-SL21	-SL23	-FD11	-FD13
Dark-ON	-ST12	-ST14	-FT12	-FT14	-SR12	-SR14	-SL12	-SL14	-SL22	-SL24	-FD12	-FD14
Weight (with packaging)	Approx. 40 g				Approx. 20 g							
Materials	Case: PBT Lens and cover: Polycarbonate											
Accessories	Phillips-head screws (side-view type: M2 x 14, flat type: M2 x 8), nuts, spring washers, flat washers, instruction sheet, and Reflector (for retroreflective model only)											

**Note:** Set the distance between the Sensor and Reflector to a value larger than the one indicated in parentheses.

## Engineering Data

### Excess Gain vs. Set Distance (Typical)

**E3T-ST1j (Through-beam)**

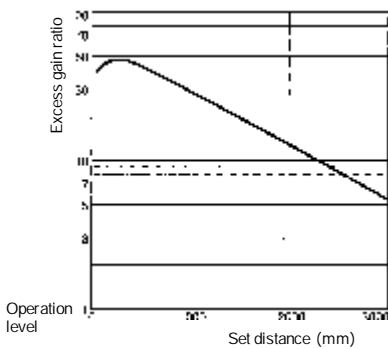

**E3T-FT1j (Through-beam)**

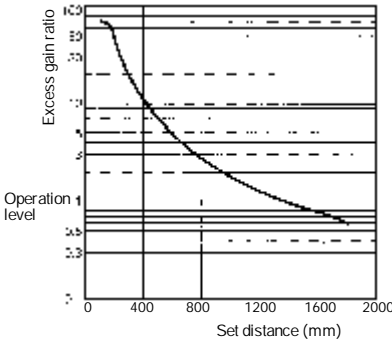

**E3T-SR1j with E39-R4 (Retroreflective)**

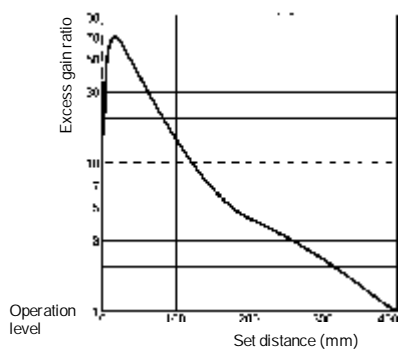

**E3T-FD1j (Diffuse Reflective)**

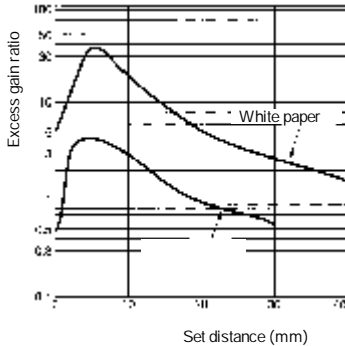

**E3T-SL1j (Limited Reflective)**

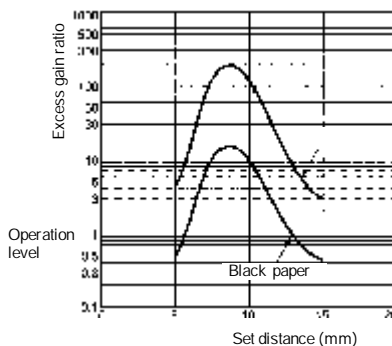

**E3T-SL2j (Limited Reflective)**

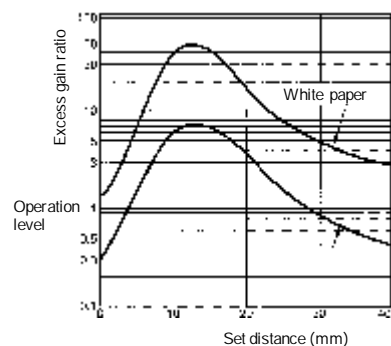

**Parallel Operating Range (Typical)  
(Through-beam)**

**E3T-ST1j with Slit**

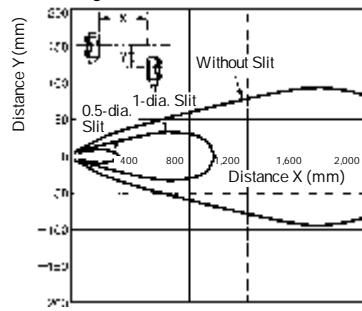

**E3T-ST1j with Slit (Enlarged graph)**

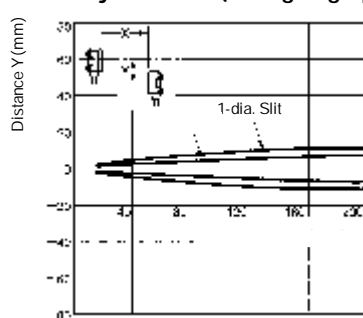

**(Retroreflective)**

**E3T-SR1j with E39-R4**

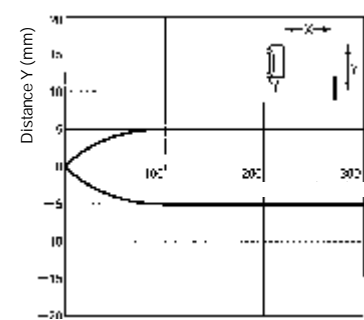

**E3T-FT1j with Slit**

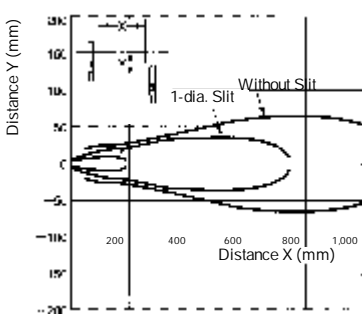

**E3T-FT1j with Slit (Enlarged graph)**

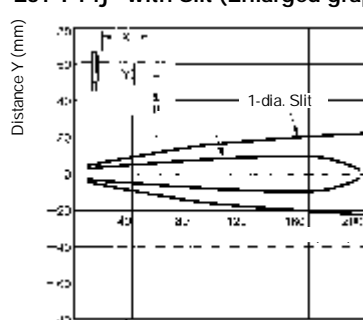

**Angle Characteristics (Typical)**

**E3T-SL1j**

(Up and Down)

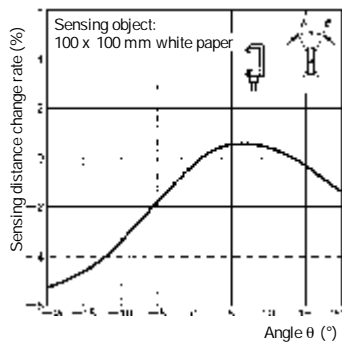

**E3T-SL1j**

(Left and Right)

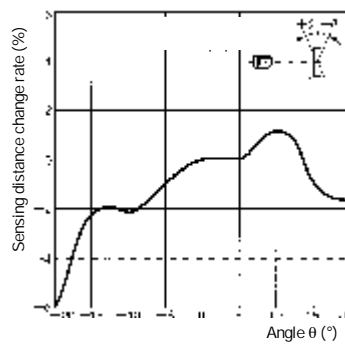

**Close-distance Sensing Capability (Typical)**

**E3T-SL1j , E3T-SL2j , E3T-FD1j**

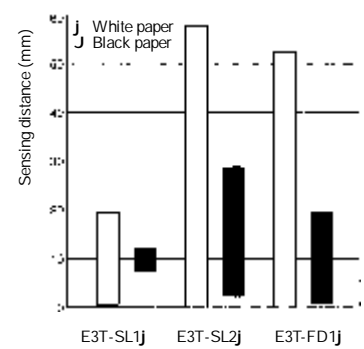

**Sensing Object Size vs. Sensing Distance (Typical)**

**E3T-SL1j**

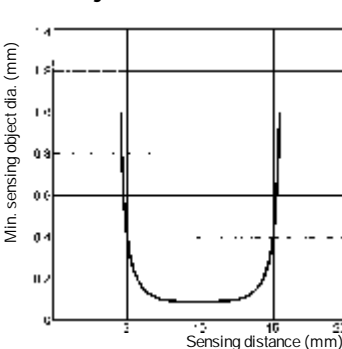

**E3T-FD1j , E3T-SL2j**

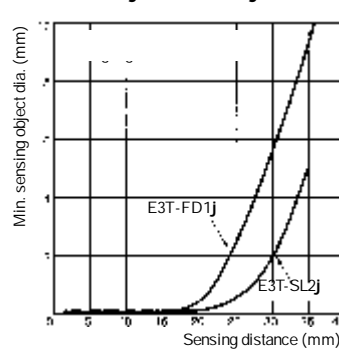

### Operation Range (Typical)

#### E3T-FD1j (Diffuse Reflective)

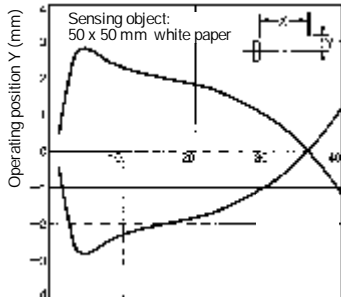

#### E3T-SL1j (Limited Reflective)

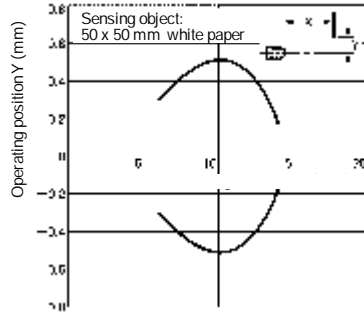

#### E3T-SL2j (Limited Reflective)

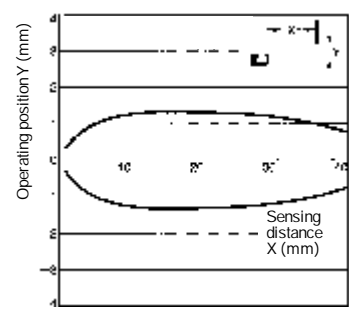

### Sensing Distance Characteristics of Sensitivity Adjustment Unit (when completing optical axis adjustment)

#### E3T-SL1j with E39-E10

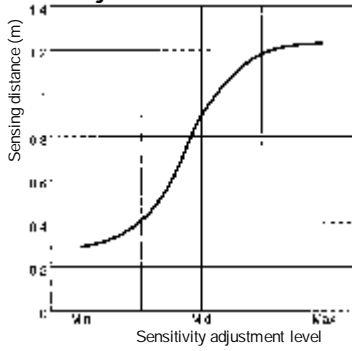

# Operation

## ■ Output Circuits

### NPN Output Configuration

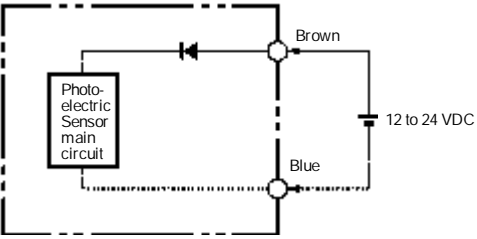
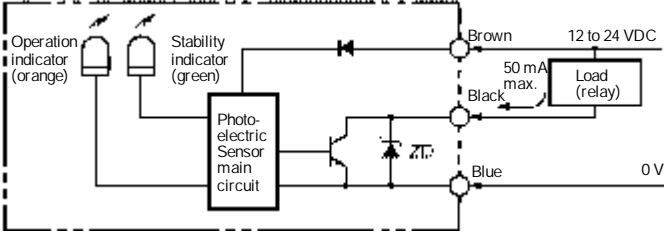
Model	E3T-j j j 1	E3T-j j j 2
State of output transistor	Light ON	Dark ON
Timing chart	<p>Light received </p> <p>Light not received </p> <p>Operation indicator (orange) ON </p> <p>OFF </p> <p>Output transistor ON </p> <p>OFF </p> <p>Load Operate </p> <p>Release </p> <p>(Between brown and black)</p>	<p>Light received </p> <p>Light not received </p> <p>Operation indicator (orange) ON </p> <p>OFF </p> <p>Output transistor ON </p> <p>OFF </p> <p>Load Operate </p> <p>Release </p> <p>(Between brown and black)</p>
Output circuit	<p>Emitter (Through-beam Models)</p>  <p>Receiver (Through-beam Models), Retroreflective, Diffuse Reflective, and Limited Reflective Models</p> 	

PNP Output Configuration

Model	E3T-j j j 3	E3T-j j j 4
State of output transistor	Light ON	Dark ON
Timing chart	<p>Light received </p> <p>Light not received </p> <p>Operation indicator (orange) ON </p> <p>OFF </p> <p>Output transistor ON </p> <p>OFF </p> <p>Load (relay) Operate </p> <p>Release </p> <p>(Between brown and black)</p>	<p>Light received </p> <p>Light not received </p> <p>Operation indicator (orange) ON </p> <p>OFF </p> <p>Output transistor ON </p> <p>OFF </p> <p>Load (relay) Operate </p> <p>Release </p> <p>(Between brown and black)</p>
Output circuit	<p>Emitter (Through-beam Models)</p> <p>Receiver (Through-beam Models), Retroreflective, Diffuse Reflective, and Limited Reflective Models</p>	

# Dimensions

Note: All units are in millimeters unless otherwise indicated.

## ■ Photoelectric Sensors

### Through-beam Models (Side-view Type)

E3T-ST1j (Emitter)

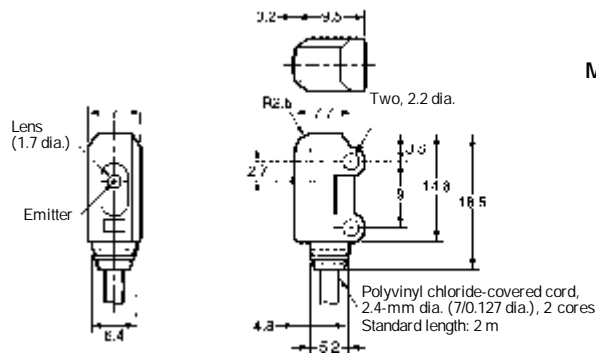

Mounting Holes

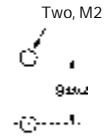

(Receiver)

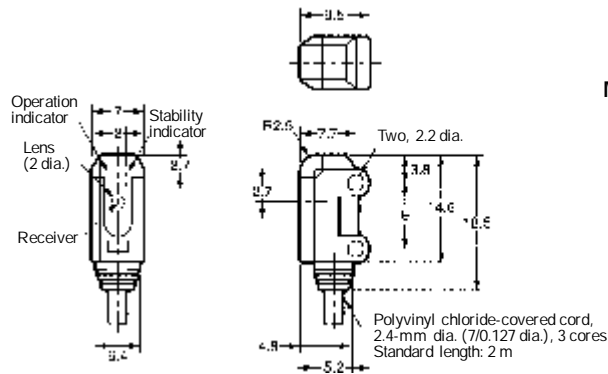

Mounting Holes

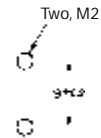

### Retroreflective Models (Side-view Type)

E3T-SR1j

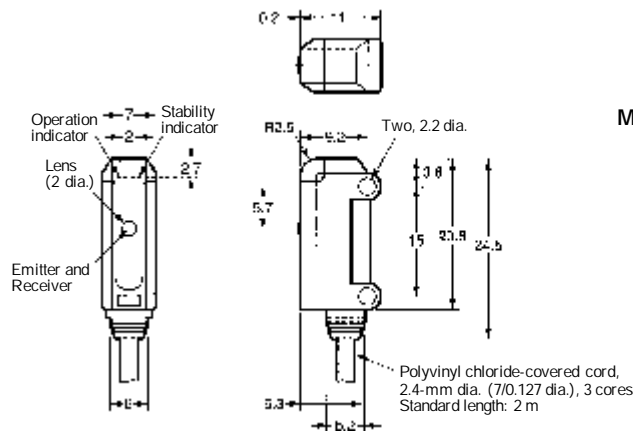

Mounting Holes

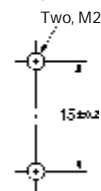

Limited Reflective Models (Side-view Type)

E3T-SL1j  
E3T-SL2j

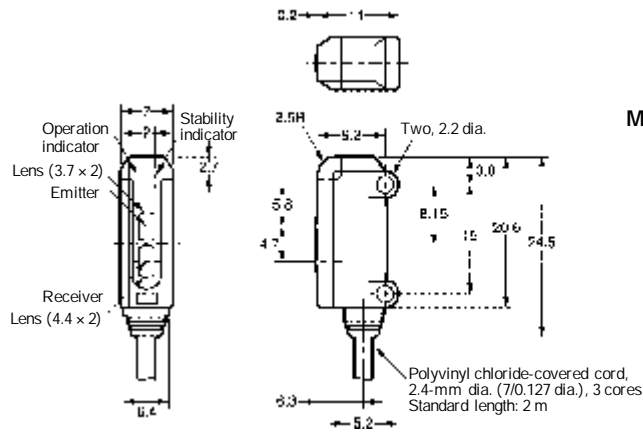

Mounting Holes

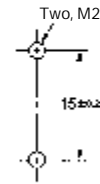

Through-beam Models (Flat Type)

E3T-FT1j  
(Emitter, Receiver)

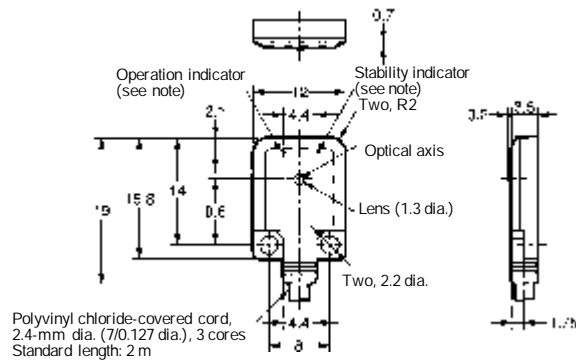
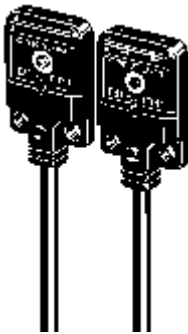

Mounting Holes

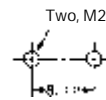

Note: For E3T-FT11/-FT13 and E3T-FT12/-FT14 Receivers only.

Diffuse Reflective Models (Flat Type)

E3T-FD1j

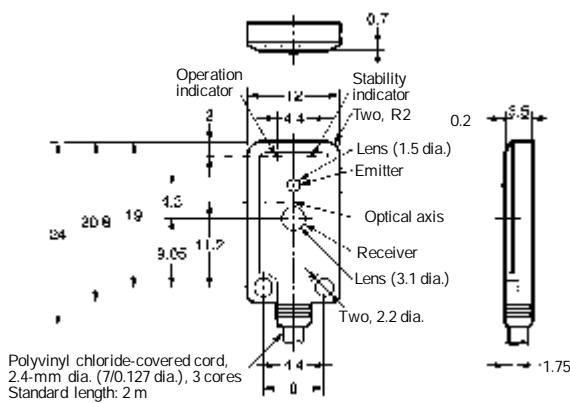

Mounting Holes

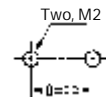

■ Accessories

Reflector (Attached to Retroreflective Models)

E39-R4



Material  
Surface: Acrylic  
Back: ABS

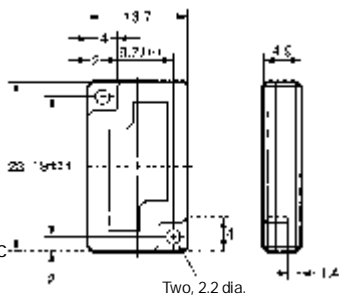

E39-R37

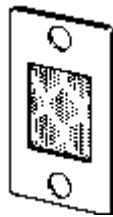

Mounting Plate

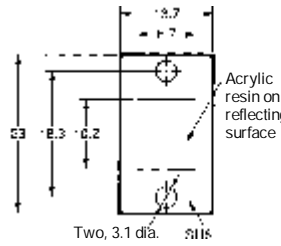

Reflector

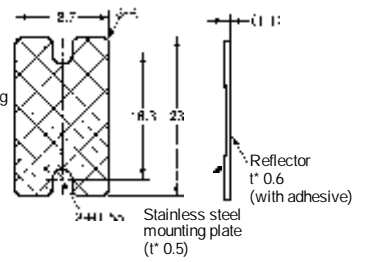

**Note:** A reflector and a stainless steel mounting plate are supplied together as a set.

Slits (Order Separately)

Through-beam E3T-ST1j with E39-S63 With Slit mounted

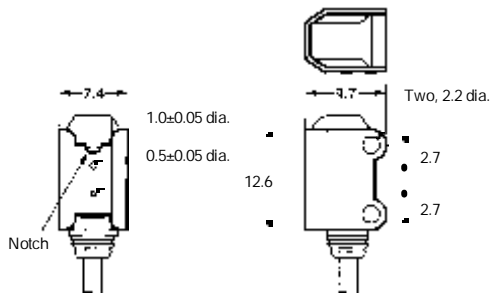

**Note:** Align the notch direction of the Slit when installing on the Emitter and Receiver.

Material: 0.2-mm-thick stainless steel (SUS301)

E39-S64 (for Through-beam E3T-FT1j ) With Slit mounted

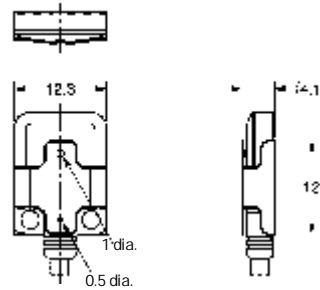

Material: 0.2-mm-thick stainless steel (SUS301)

Sensitivity Adjustment Unit (for E3T-ST1j )

E39-E10

When the Sensitivity Adjustment Unit is mounted

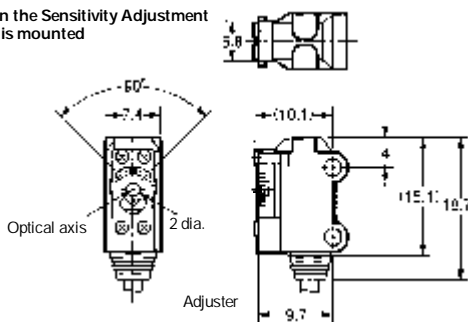

Material: Stainless steel (SUS301)

Mounting Brackets for E3T-Sj (Order Separately)

E39-L116

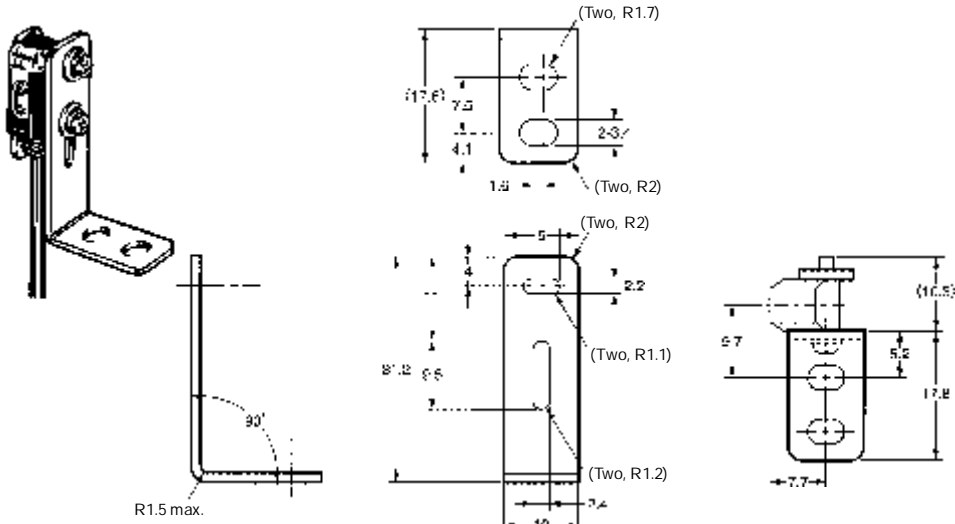

Material: 1.2-mm-thick stainless steel (SUS304)

E3T-ST11 with E39-L116

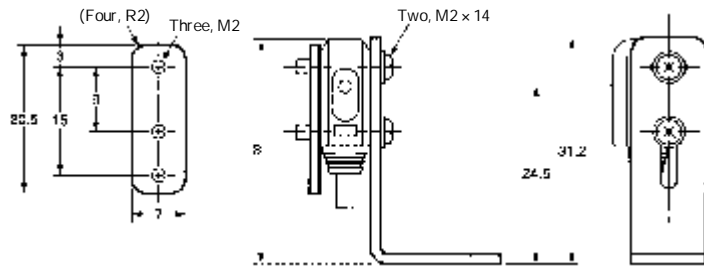

E39-L117

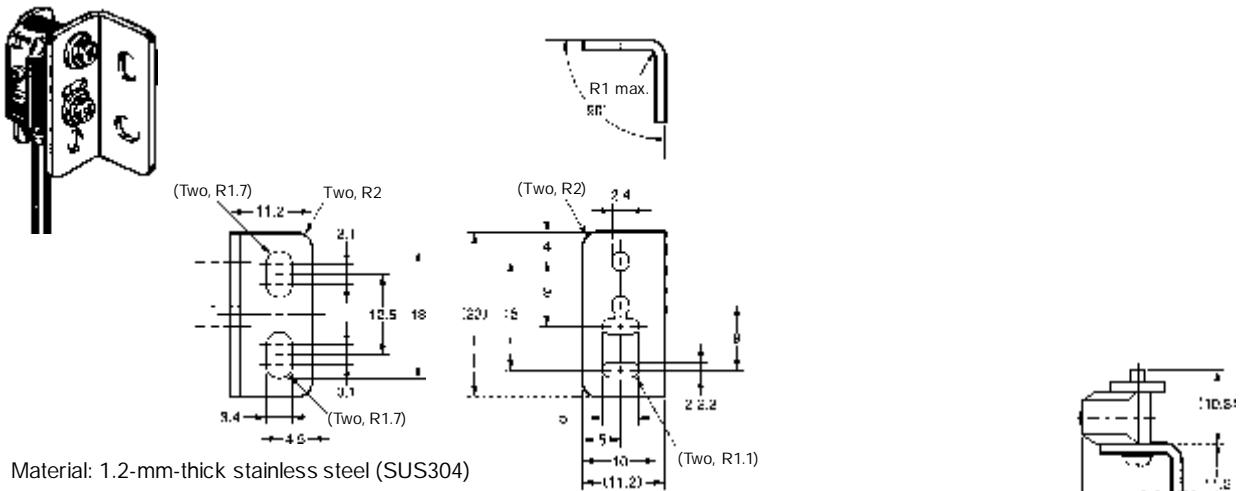

Material: 1.2-mm-thick stainless steel (SUS304)

E3T-ST11 with E39-L117

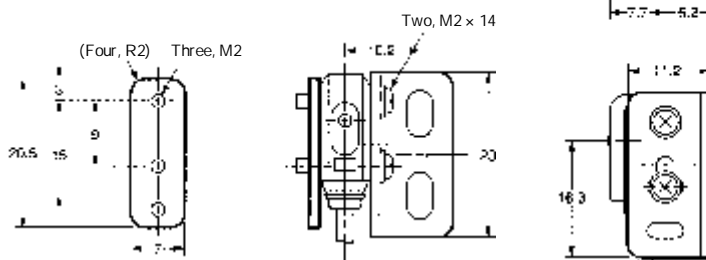

E39-L118

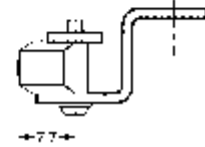
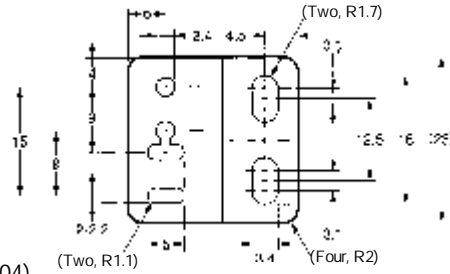
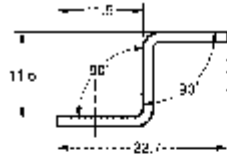

Material: 1.2-mm-thick stainless steel (SUS304)

E3T-ST11 with E39-L118

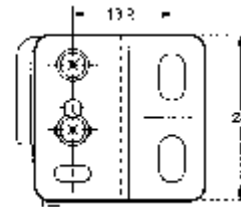
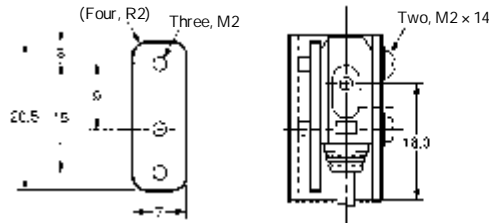

Mounting Brackets for E3T-FT1j /E3T-FD1j

E39-L119

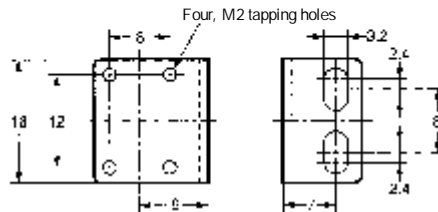
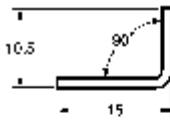
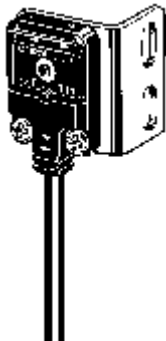

E3T-FT11 with E39-L119

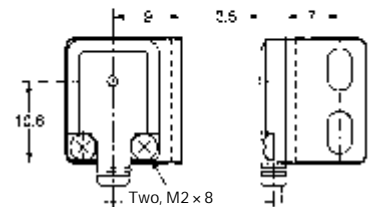
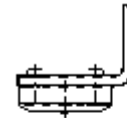

Material: 1.2-mm-thick stainless steel (SUS304)

E39-L120

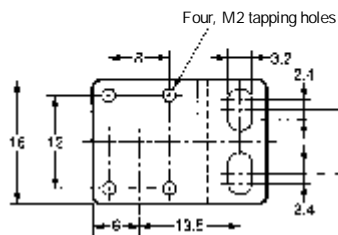
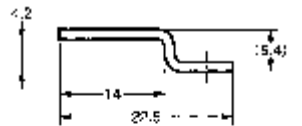
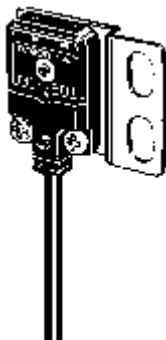

E3T-FT11 with E39-L120

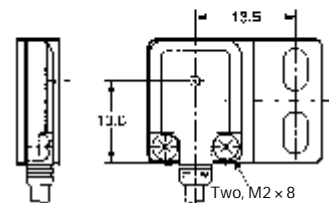
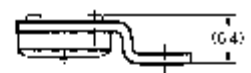

Material: 1.2-mm-thick stainless steel (SUS304)

## Precautions



Do not apply AC power to the E3T, otherwise the E3T may be damaged.

Do not impose any voltage exceeding the rated voltage on the E3T, otherwise the E3T may be damaged.

Do not short-circuit the load connected to the E3T, otherwise the E3T may be damaged.

When supplying power to the E3T, make sure that the polarity of the power is correct, otherwise the E3T may be damaged.

### Correct Use

#### Operating Environment

Do not install the E3T in the following places. Doing so may cause the E3T to malfunction.

- Places where the E3T is exposed to direct sunlight.
- Places with high humidity and where condensation may result.
- Places with corrosive gas
- Places with vibration or shock affecting the E3T

#### High-tension Lines

The power supply lines of the Photoelectric Sensor must not be wired alongside power lines or high-tension lines in the same conduit, otherwise the Photoelectric Sensor may become damaged or malfunction due to induction noise that may be generated from the power lines or high-tension lines.

#### Cord

The cord can be extended up to 100 m provided that the thickness of the cord is 0.3 mm<sup>2</sup> maximum.

#### Power Supplies

Be sure to ground the FG (frame ground) and G (ground) terminals if a switching regulator is connected to the E3T, otherwise the E3T may malfunction due to the switching noise of the switching regulator.

#### Water Resistivity

Do not use the E3T underwater, outdoors, or in the rain.

#### Load short-circuit protection

The E3T incorporates a load short-circuit protection function. If the load short-circuits, the output of the E3T will be turned OFF. Then, recheck the wiring and turn on the E3T again to reset the load short-circuit protection function. The load short-circuit protection function will work if there is a current flow that is 2.4 times larger than the rated load current. When using an inductance load, be sure that the inrush current will not exceed 2.4 times larger than the rated current.

#### Cleaning

Paint thinner will damage the casing of the E3T. Do not apply paint thinner when cleaning the E3T.

#### Others

When mounting the E3T, do not strike the E3T with a hammer. Otherwise, the E3T will lose its watertight properties. Use M2 screws and washers to mount the E3T.

## Indicators

The following graphs indicate the status of each operation level. Be sure to use the E3T within the stable operating range.

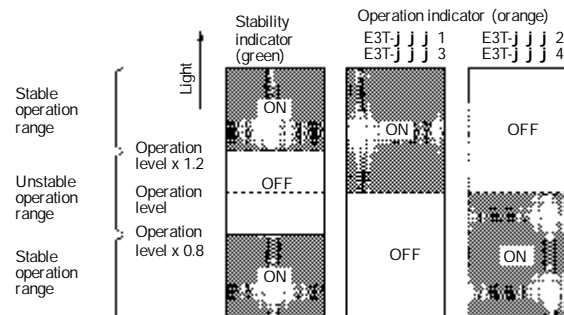

**Note:** If the E3T's operation level is set to the stable operation range, the E3T will be in most reliable operation without being influenced by temperature change, voltage fluctuation, dust, or setting change. If the operation level cannot be set to the stable operation range, pay attention to environmental changes while operating the E3T.

### Use of E39-E10 Sensitivity Adjustment Unit

(Dark ON: E3T-ST12/ST14)

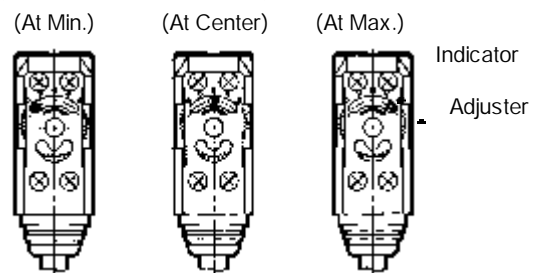

1. Mount the Unit on the Receiver.
2. Set the adjuster of the Sensitivity Adjustment Unit to Max. (Before shipping: Max.)
3. After mounting on the Sensor, adjust the optical axis and secure the Sensor.
4. Place a workpiece between the Emitter and Receiver and gradually turn the adjuster counterclockwise toward the Min. side. Stop turning the adjuster when the operation indicator and stability indicator (green) turn ON.
5. Remove the workpiece and confirm that the operation indicator is OFF and the stability indicator (green) is ON. This completes the adjustment.

**Note:** If the light attenuation rate due to a workpiece is 40% or less, the stability indicator will not turn ON whether or not light is received. When the variation of light is small such as when sensing semi-transparent workpieces, carefully perform preliminary testing.

### Turning ON Power Supply

The E3T will become ready for sensing 100 ms after the power is turned ON.

If the E3T is connected to a power source different from one for loads, be sure to turn ON the power supply to the E3T first.



# OMRON

## OMRON Corporation

Industrial Automation Company

Industrial Sensors Division  
Sensing Devices and Components Division H.Q.  
28th Fl., Crystal Tower Bldg.,  
1-2-27, Shiromi, Chuo-ku, Osaka 540-6028 Japan  
Phone: (81)6-6949-6012 Fax: (81)6-6949-6021

### *Regional Headquarters*

#### **OMRON EUROPE B.V.**

Wegalaan 67-69, NL-2132 JD Hoofddorp  
The Netherlands  
Tel: (31)2356-81-300/Fax: (31)2356-81-388

#### **OMRON ELECTRONICS, INC.**

1 East Commerce Drive, Schaumburg, IL 60173  
U.S.A.  
Tel: (1)847-843-7900/Fax: (1)847-843-8568

#### **OMRON ASIA PACIFIC PTE. LTD.**

83 Clemenceau Avenue,  
#11-01, UE Square,  
Singapore 239920  
Tel: (65)835-3011/Fax: (65)835-2711

**Authorized Distributor:**

**ALL DIMENSIONS SHOWN ARE IN MILLIMETERS.**

To convert millimeters into inches, multiply by 0.03937. To convert grams into ounces, multiply by 0.03527.