

Fluid level sensor (contact type)

E32-D82F

High-accuracy detection of fluid level in washing tank.

- Uses Teflon (PFA) with excellent chemical and oil resistance.
- Can also detect high-temperature fluids such as sulfuric acid in a wafer washing tank. (-40 to +200°C)
- Achieves a high repetition precision of 0.5 mm (in pure water).
- Employs a dripping prevention mechanism.



Ordering Information

Fiber Units

Sensor type	Shape	Model	Remarks
Diffuse-reflective		E32-D82F1	Length of no-bending section: 150 mm from tip
		E32-D82F2	Length of no-bending section: 350 mm from tip

Applicable amplifier unit

Model
E3X-DA-N
E3X-NA

Rating/performance

Sensor type		Diffuse-reflective	
Item	Model	E32-D82F1	E32-D82F2
Standard sensing object		Pure water at 25°C	
Differential distance		3 mm max.	
Repetition precision		0.5 mm or less	
Permissible angle of detection object inclination		±10° or less	
Perimeter temperature	Teflon section within 1.5 m of fiber tip*1	Operating: -40 to +200°C, Storage: -40°C to +85°C (with no icing or condensation)	
	Parts other than the above	Operating/storage: -40 to +85°C (no ice formation or condensation)	
Ambient humidity		Operating/storage: 35 to 85% RH	
Peripheral pressure		Operating: -50 kPa to 500 kPa	
Permissible bending radius (10% under fluid level)		40 mm or greater (25 mm for plastic fiber section)	
average)	Length of no-bending section	150 mm from tip	350 mm from tip
Material	Sensor case	Teflon (PFA)	
	Fiber cladding	Black polyethylene	
	Connector	Brass-nickel coating	
Protective structure		IEC Standard IP68*2	
Weight (Packed state)		Approx. 75 g	
Accessories		Fiber cutter	

*1. Teflon is a registered trademark of the Dupont Company and the Mitsui Dupont Chemical Company for their fluoride resin.

*2. Only applies to Teflon section; the standard requires no bubbling when air at 98 kPa is injected for 30 seconds at a depth of 100 mm in water.

Principle of operation

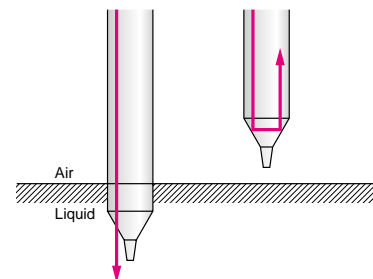

- In air, the difference between the index of refraction of the Teflon section and that of air is larger, and the light is reflected by the detected surface and returns to the light receiver.
- In the fluid, there is almost no difference between the index of refraction of the Teflon section and that of the fluid, and the light radiates into the fluid.

Operation

● Teaching type

1. Using teaching without work

Perform teaching with the tip of the fiber unit in the fluid. (The sensitivity is set to the top 10% of the received light intensity in fluid for stronger performance with respect to fluctuations in received light intensity due to running out of fluid, and thus teaching without work for high viscosity fluids is effective.)

2. Using teaching with/without work

Perform teaching after the object has been removed from the fluid, and then perform teaching again with the object in the fluid. (Teaching with/without work is effective for fluids in which bubbles form at high temperature.)

Note: If set to the maximum sensitivity with the object removed from the fluid, detection of the fluid will no longer be possible.

● Sensitivity control type

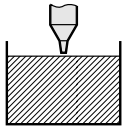
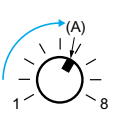
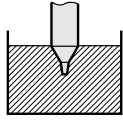
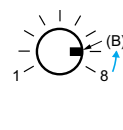
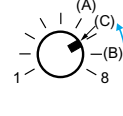
Sequence	Detection state	Sensitivity adjuster	Indicator state		Adjustment procedure
1			Green OFF	Red OFF	Determine the position A at which the incident light indicator lamp (red) illuminates as the sensitivity control is gradually increased from the minimum setting after the object has been removed from the fluid.
2			Green OFF	Red OFF	<ul style="list-style-type: none"> If the red indicator lamp illuminates at the maximum sensitivity setting, gradually decrease the sensitivity control from the maximum setting with the object in the fluid, and determine the position B at which the incident light indicator lamp (red) goes off. If the red indicator lamp goes off at the maximum sensitivity
3	---		Green ON	Red OFF	Set the sensitivity control to C midway between A and B. At this time, verify that the stability indicator lamp (green) illuminates both with and without fluid.

Precautions

Correct Use

Mounting

- Use the no-bending section to secure the fiber unit. If the fiber unit is secured without using the no-bending section, the fluid level detection position may shift.
- Effects from the sides or bottom may interfere with detection. In that case, remove to a distance that is not subject to these effects, or apply a black coating to the sides and bottom.
- If you need to use the system in a dangerous location, use only the fiber unit in the dangerous location and place the amplifier unit in a safe location.

● For adjustment

About the fluid level detection position

The fluid level detection position is located 5.2 ± 2 mm from the tip of the Teflon section (see the diagram at right). The fluid level detection

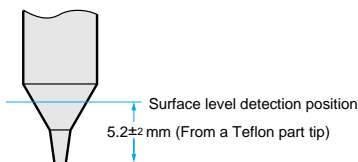

position will vary depending on the surface tension of the fluid and the dampness of the detection position of the fiber unit.

Others

- Operation will not be stable in the following situations. ① Bubbles adhere to the cone of the detector head. ② Solutes have precipitated onto the cone of the detector head. ③ The fluid has a high viscosity.
- Some fluids such as those of a milky-white color may not permit detection.
- Take care not to strike the tip with any object. A damaged or deformed detector head may cause unstable operation.

Dimensions (Unit: mm)

E32-D82F1
E32-D82F2

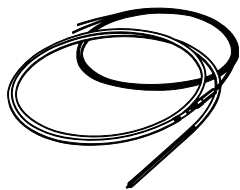

CAD file E32_16

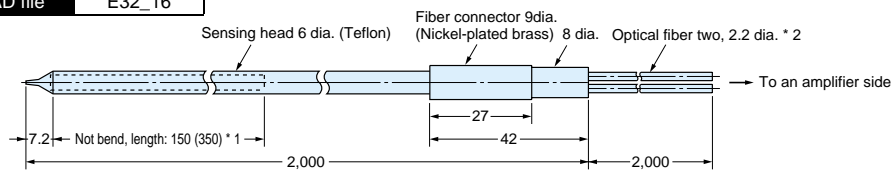

* 1. (): E32-D82F2 dimensions

* 2. Freely cut because 2m part of optical fiber at amplifier side is made from a plastic fiber.