

Enclosed Switch ZC-□55

Small, High-precision Enclosed Switch

- Employs a modified version of Z Basic Switch as built-in switch.
- Same mounting pitch as Z Basic Switch.
- Pre-wired molded terminal models are available.
- Requires less operating force than conventional limit switches.
- Long life expectancy and economical.
- Approved by EN, UL, CSA, and CCC (Chinese standard).

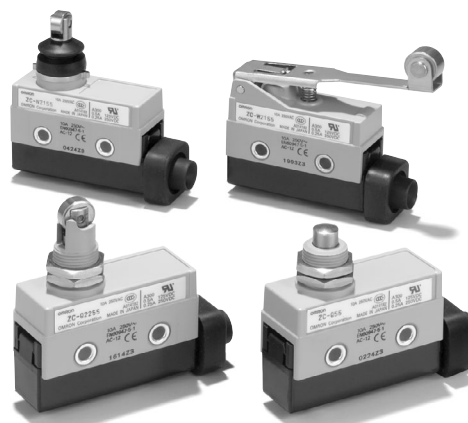

Model Number Structure

Model Number Legend













ZC-□55
1

1. Actuator

- | | |
|--------------------------------------|---|
| D: Plunger | W: Short hinge lever |
| Q: Panel mount plunger | W1: Hinge lever |
| Q22: Panel mount roller plunger | W2: Short hinge roller lever |
| Q21: Panel mount crossroller plunger | W21: Hinge roller lever |
| N22: Sealed roller plunger | W3: One-way action short hinge roller lever |
| N21: Sealed crossroller plunger | W31: One-way action hinge roller lever |

Ordering Information

List of Models

Actuator	Model	Actuator	Model
Plunger 	ZC-D55	Short hinge lever 	ZC-W55
Panel mount plunger 	ZC-Q55	Hinge lever 	ZC-W155
Panel mount roller plunger 	ZC-Q2255	Short hinge roller lever 	ZC-W255
Panel mount crossroller plunger 	ZC-Q2155	Hinge roller lever 	ZC-W2155
Sealed roller plunger 	ZC-N2255	One-way action short hinge roller lever 	ZC-W355
Sealed crossroller plunger 	ZC-N2155	One-way action hinge roller lever 	ZC-W3155

Note: Use molded terminal models (refer to page 121) when using the Switch under one of the following conditions:
a) dusty, b) high amount of dripping oil, or c) high humidity

Terminal Protective Cover, Seal Rubber, and Rubber Packing

(The Switch is equipped with these 3 items as a standard.)

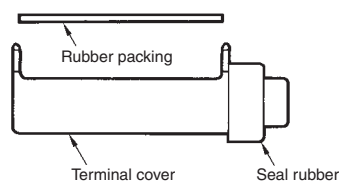

- ZC Terminal Cover
(Product code: ZC55-0002H)
- ZC Seal Rubber
(Product code: SC-1404C)
- ZC Rubber Packing
(Product code: ZC55-0003F)

Specifications

■ Approved Standards

(Except Molded Terminal Models and Operation Indicator-equipped Model)

Agency	Standard	File No.
UL	UL508	E76675
CSA	C22.2, No. 14	LR45258
TÜV Rheinland	EN60947-1, EN60947-5-1	J9650089
CCC (CQC)	GB14048.5	2003010303077620

Note: Ask your OMRON representative for information on approved models.

■ Approved Standard Ratings

UL/CSA

A300

Voltage	Carry current	Current		Volt-amperes	
		Make	Break	Make	Break
120 VAC	10 A	60 A	6 A	7,200 VA	720 VA
240 VAC		30 A	3 A		

TÜV Rheinland (EN60947-1, EN60947-5-1), CCC (GB14048.5)

Applicable category and ratings
AC-12 10 A/250 VAC

■ General Ratings

Rated voltage	Non-inductive load				Inductive load			
	Resistive load		Lamp load		Inductive load		Motor load	
	NC	NO	NC	NO	NC	NO	NC	NO
125 VAC	10 A		3 A	1.5 A	10 A		5 A	2.5 A
250 VAC	10 A		2.5 A	1.25 A	10 A		3 A	1.5 A
8 VDC	10 A		3 A	1.5 A	6 A		5 A	2.5 A
14 VDC	10 A		3 A	1.5 A	6 A		5 A	2.5 A
30 VDC	6 A		3 A	1.5 A	5 A		5 A	2.5 A
125 VDC	0.5 A		0.4 A	0.4 A	0.05 A		0.05 A	0.05 A
250 VDC	0.25 A		0.2 A	0.2 A	0.03 A		0.03 A	0.03 A

Inrush current	NC	30 A max.
	NO	15 A max.

- Note:**
- The above figures are for steady-state currents.
 - Inductive loads have a power factor of 0.4 min. (AC) and a time constant of 7 ms max. (DC).
 - Lamp load has an inrush current of 10 times the steady-state current.
 - Motor load has an inrush current of 6 times the steady-state current.
 - The above ratings were tested under the following conditions according.
 - Ambient temperature: 20±2°C
 - Ambient humidity: 65±5%
 - Operating frequency: 20 operations/min

■ Characteristics

Degree of protections	IP67
Durability	Mechanical: 10,000,000 operations min. Electrical: 500,000 operations min.
Operating speed	0.05 mm to 0.5 m/s (at pin plunger)
Operating frequency	Mechanical: 120 operations/min Electrical: 20 operations/min
Insulation resistance	100 MΩ min. (at 500 VDC)
Contact resistance	15 mΩ max. (initial value)
Dielectric strength	1,000 VAC, 50/60 Hz for 1 min between non-continuous terminals 2,000 VAC, 50/60 Hz for 1 min between current-carrying metal part and ground, and between each terminal and non-current-carrying metal parts
Rated insulation voltage (U _i)	1,000 VAC
Pollution degree (operating environment)	3 (IEC947-5-1)
Short-circuit protective device	10 A-fuse type gG (IEC 269)
Protection against electric shock	Class II
PT1 (tracking characteristics)	175
Switch category	D (IEC335)
Rated operating current (I _e)	10 A
Rated operating voltage (U _e)	250 VAC
Vibration resistance	Malfunction: 10 to 55 Hz, 1.5-mm double amplitude (see note)
Shock resistance	Destruction: 1,000 m/s ² max. Malfunction: 300 m/s ² max. (at pin plunger) (see note)
Ambient temperature	Operating: -10°C to 80°C (with no icing)
Ambient humidity	Operating: 35% to 95%
Weight	Approx. 92 g (in case of ZC-Q22(21)55)

Note: Less than 1 ms under a free state at the operating limits.

Connections

■ Contact Form

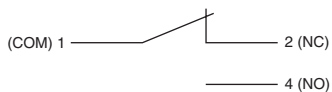

■ Operation Indicator-equipped Models

All the models can be equipped upon request with an operation indicator to facilitate maintenance and inspection.

Because the indicator is incorporated in the Terminal Protective Cover, the dimensions of the Limit Switch are not affected. In this model, the lead wire is to be connected to the screw terminal. (A connecting washer is provided on the tip of the lead wire).

The lead wire can be connected to either the NC or NO terminal.

Operating characteristics are the same as the standard model from which the operation indicator equipped model is fabricated.

AC Operation

The operating voltage range is from 90 to 250 VAC.

The dimensions are the same as the standard type. The top of the Terminal Protective Cover is transparent to allow checking the operation easily.

When placing your order for the indicator equipped, AC-operated model, add suffix "L" to the end of the model number.

Example:

Standard type: ZC-Q2255
Indicator equipped type: ZC-Q2255-L

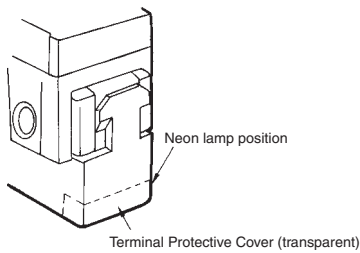

Contact Circuit

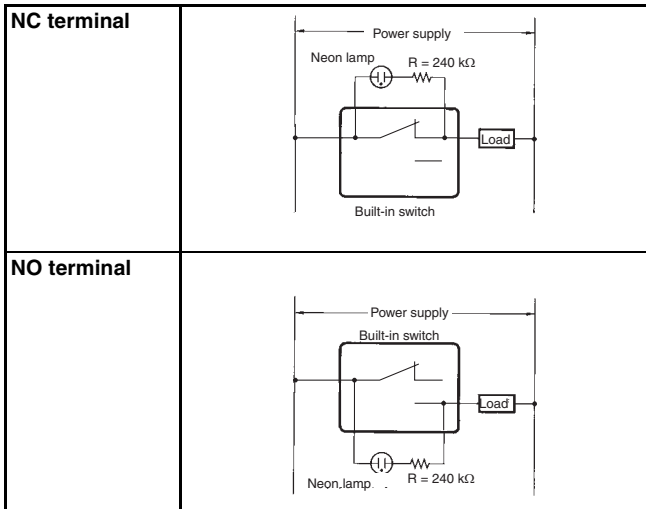

Note: If the wiring is as shown above, the operation of the respective parts will be as shown in the following table. The neon lamp is not wired when the Switch is delivered. Connect it as required.

Contact	Neon lamp	Load	Actuator
NC	ON	Does not operate	Operates
	OFF	Operates	Does not operate
NO	ON	Does not operate	Does not operate
	OFF	Operates	Operates

DC Operation

The DC-operated is provided with an LED indicator.

There is no protective structure.

Since a rectifier stack is incorporated into the unit to permit reversing the polarity, this type can also operate on AC power source.

The LED projects from the housing for easy visibility.

When placing your order, add suffix "L2" or "L4" to the model number of the standard type.

Example:

Standard type: ZC-Q2255
Indicator equipped type: ZC-Q2255-L2

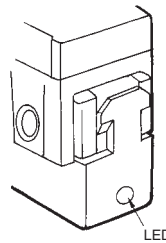

Type	Voltage rating	Leakage current	Internal resistance
L2	12 V	Approx. 2.4 mA	4.3 kΩ
L4	24 V	Approx. 1.2 mA	18 kΩ

Contact Circuit

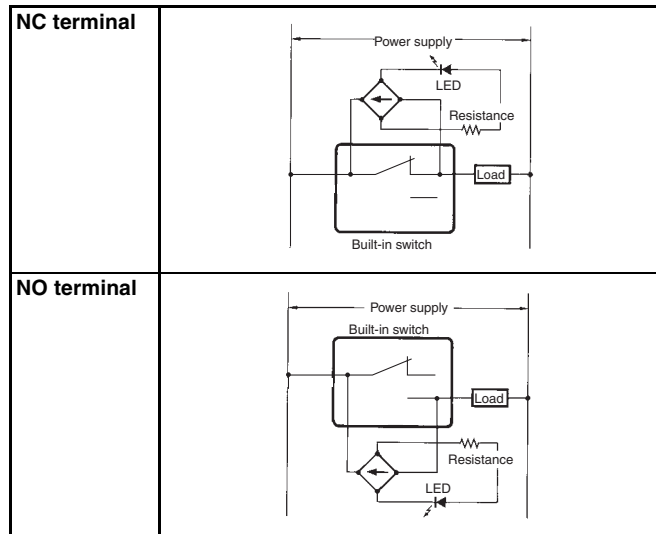

Note: If the wiring is as shown above, the operation of the respective parts will be as shown in the following table. The LED terminals are not wired when the Switch is delivered. Connect it as required.

Contact	LED	Load	Actuator
NC	ON	Does not operate	Operates
	OFF	Operates	Does not operate
NO	ON	Does not operate	Does not operate
	OFF	Operates	Operates

Nomenclature

Changing the Terminal Protective Cover around allows the cable to be pulled out from either the right or the left.

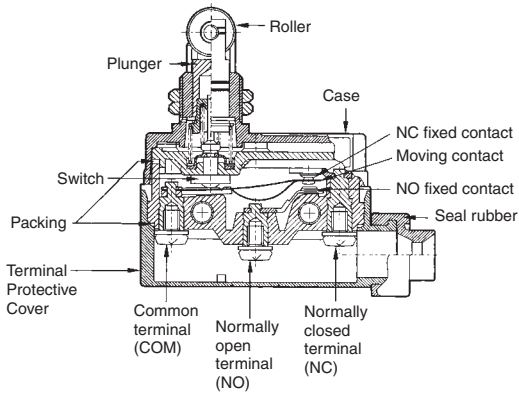

Note: M4 binding head screws (with toothed washers) are used as the terminal screws.

Engineering Data

■ Mechanical Durability (for ZC-Q55)

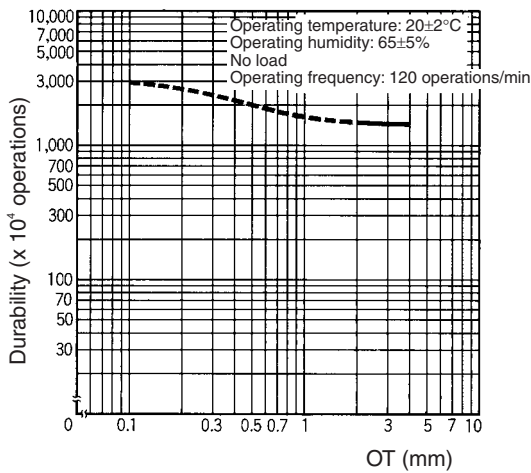

■ Electrical Durability

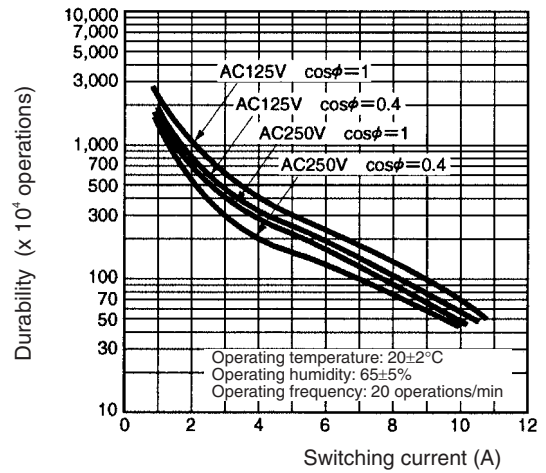

Dimensions

- Note:** 1. All units are in millimeters unless otherwise indicated.
 2. Unless otherwise specified, a tolerance of ± 0.4 mm applies to all dimensions.

Plunger ZC-D55

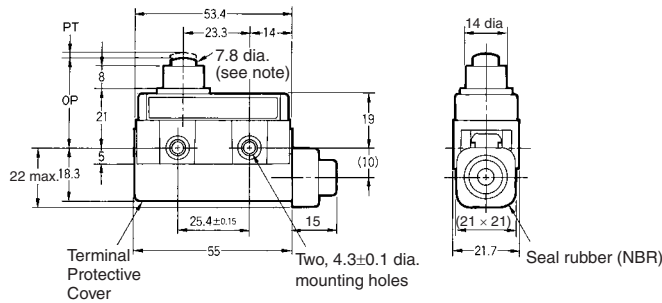

Note: Stainless steel plunger

Model	ZC-D55
OF max.	11.8 N
RF max.	4.90 N
PT max.	1.5 mm
OT min.	2.4 mm
MD max.	0.2 mm
OP	32.4±0.8 mm

Panel Mount Plunger ZC-Q55

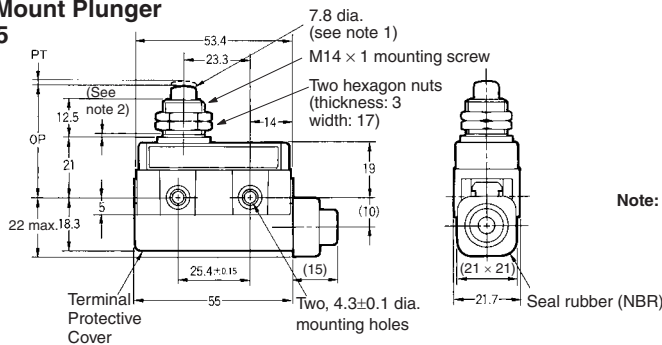

- Note:** 1. Stainless steel plunger
 2. The length of the imperfect threads is 1.5 mm maximum.
 3. Do not use the M14 mounting screw and the case mounting hole at the same time.

Model	ZC-Q55
OF max.	11.8 N
RF max.	4.90 N
PT max.	1.5 mm
OT min.	3 mm
MD max.	0.2 mm
OP	38.2±0.8 mm

Panel Mount Roller Plunger ZC-Q2255

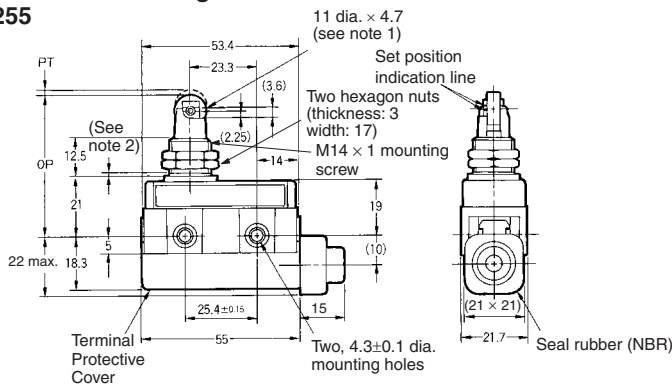

- Note:** 1. Stainless sintered alloy roller
 2. The length of the imperfect threads is 1.5 mm maximum.
 3. Do not use the M14 mounting screw and the case mounting hole at the same time.

Model	ZC-Q2255
OF max.	11.8 N
RF max.	4.90 N
PT max.	1.5 mm
OT min.	3 mm
MD max.	0.2 mm
OP	47.4±0.8 mm

Panel Mount Crossroller Plunger ZC-Q2155

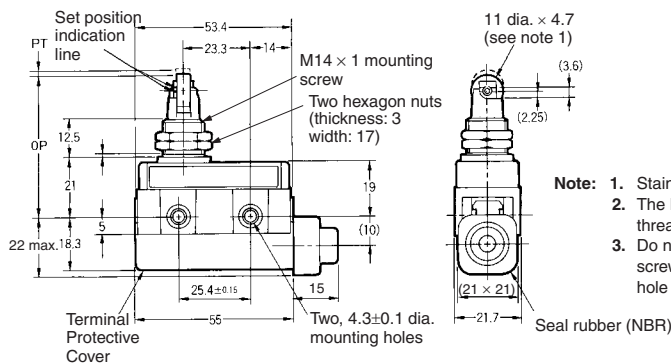

- Note:** 1. Stainless sintered alloy roller
 2. The length of the imperfect threads is 1.5 mm maximum.
 3. Do not use the M14 mounting screw and the case mounting hole at the same time.

Model	ZC-Q2155
OF max.	11.8 N
RF max.	4.90 N
PT max.	1.5 mm
OT min.	3 mm
MD max.	0.2 mm
OP	47.4±0.8 mm

Sealed Roller Plunger
ZC-N2255

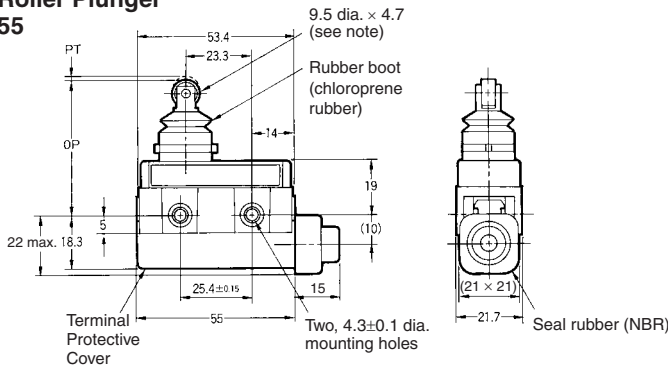

Note: Stainless sintered alloy roller

Model	ZC-N2255
OF max.	6.86 N
RF max.	1.67 N
PT max.	1.5 mm
OT min.	2.5 mm
MD max.	0.2 mm
OP	47.4±0.8 mm

Sealed Crossroller Plunger
ZC-N2155

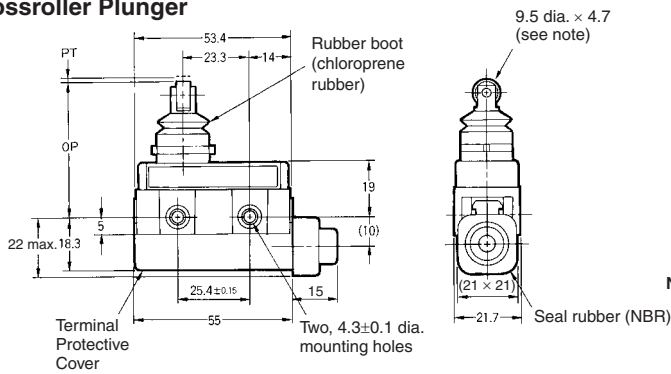

Note: Stainless sintered alloy roller

Model	ZC-N2155
OF max.	6.86 N
RF max.	1.67 N
PT max.	1.5 mm
OT min.	2.5 mm
MD max.	0.2 mm
OP	47.4±0.8 mm

Short Hinge Roller Lever
ZC-W55

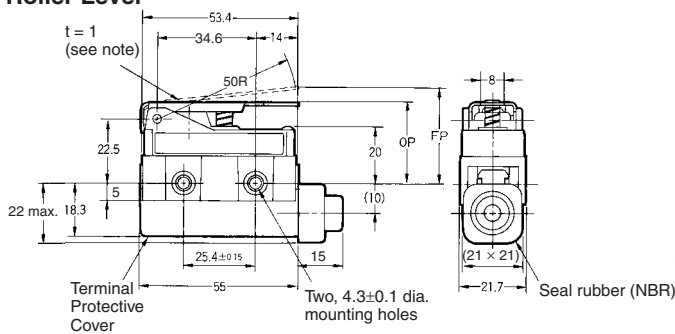

Note: Stainless steel lever

Model	ZC-W55
OF max.	3.92 N
RF max.	0.78 N
PT max.	6 mm
OT min.	1 mm
MD max.	28.5±1.2 mm
OP	34.7 mm

Hinge Lever
ZC-W155

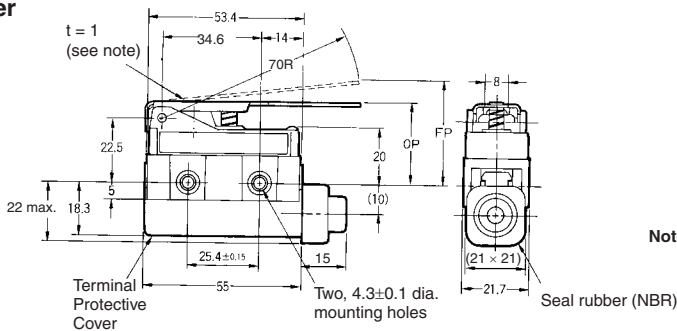

Note: Stainless steel lever

Model	ZC-W155
OF max.	2.75 N
RF max.	0.59 N
PT max.	8.4 mm
OT min.	1.4 mm
MD max.	28.5±1.2 mm
OP	36.7 mm

Molded Terminal Models

Molded Terminal Model

The molded-terminal model is available with right-hand, left-hand and underside leads and is recommended for use where the Switch is exposed to dust, oil or moisture.

The molded-terminal model is not approved by UL, CSA, or EN.

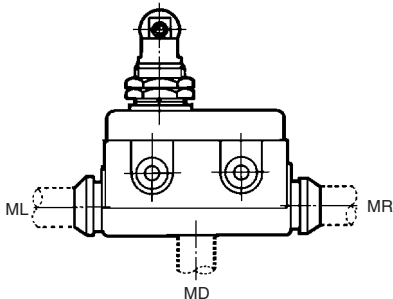

Note: When placing your order for the Switch, specify the required length of V.C.T. cable in addition to the model number of the Switch.

Example:

Standard type: ZC-Q2255
 Location of lead output: Right side
 Length of lead: 1 m (V.C.T. lead)
 When placing your order for the above Switch, specify the model number as ZC-Q2255-MR VCT 1M.

Suffix by Location of Lead Outlet

Location of lead output	Model
	COM, NC and NO
Right-hand	ZC-□-MR
Left-hand	ZC-□-ML
Underside	ZC-□-MD

Lead Supplies

Leads	Nominal cross-sectional area	Finished outside diameter	Terminal connections	Standard length
V.C.T. (vinyl cabtire cable)	1.25 mm ²	3 core: 10.5 dia.	Black: COM White: NO Red: NC	1, 3 m

Precautions

Refer to the "Precautions for All Switches" on page 17 and "Precautions for General-purpose Limit Switches (Including Multiple Limit Switches, Mechanical Touch Switches, High-precision Switches, Touch Switches, On-site Flexible Switches; Not Including Safety Switches)" on page 23.

Correct Use

Dog Angle

When operating the roller type, be sure to set the dog angle to less than 30° (even when operating at a low speed). Operating the model at a dog angle exceeding 30° will soon cause abrasion or damage. Do not apply a twisting force to the plunger. Set the OT to 70% to 100% of the specified value so that the actuator will not exceed the OT.

Handling

When detaching the Terminal Protective Cover, insert a screwdriver and apply a force in the opening direction. Do not use excess force to remove the cover. Doing so may cause deformation in the fitting section and reduce the holding force.

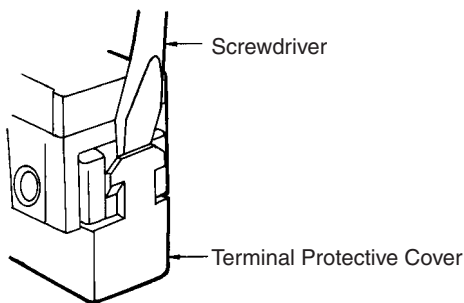

When mounting the Terminal Protective Cover to the case, align the cover on the case and then press the cover down to mount it firmly. If the cover is pressed down in an inclined position, rubber packing will deform and thus affect the sealing capability.

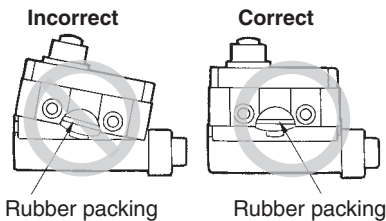

- A 8.5- to 10.5-dia. cable can be applied as seal rubber for the lead wire outlet. (Use two- or three-core cable of VCT1.25 mm².)
- Use weather-proof rubber (chloroprene rubber) as seal rubber for the ZC-N22(21)55.

Mounting

- When mounting the Switch with screws on a side surface, fasten the Switch with M4 screws and use washers, spring washers, etc., to ensure secure mounting.

Mounting Holes

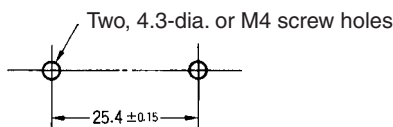

ALL DIMENSIONS SHOWN ARE IN MILLIMETERS.
To convert millimeters into inches, multiply by 0.03937. To convert grams into ounces, multiply by 0.03527.

- When mounting the Panel Mount-type Enclosed Switch (ZC-Q55, ZC-Q2255, or ZC-Q2155) with screws on a side surface, remove the hexagonal nuts from the actuator.

Mounting Hole Dimensions

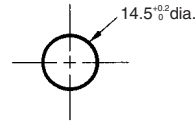

Tightening Torque

A loose screw may result in a malfunction. Be sure to tighten each screw to the proper tightening torque as shown below.

No.	Type	Torque
1	Terminal screw	0.78 to 1.18 N·m
2	Panel mounting screw	4.90 to 7.84 N·m
3	Side mounting screw	1.18 to 1.47 N·m

Operation

With the ZC-Q22(21)55, an appropriate OT line is marked on the plunger. Set the OT so that it is between the two X-surface lines.

