

Multiple Limit Switch VB

A New Monoblock Multiple Limit Switch Incorporating a Head Box with a Tough Head and Ensuring High Sealing Performance and a Mechanical Durability of 5,000,000 Operations

- Used for the sequential control of a variety of engineering machines and belt conveyor lines.
- Built-in oil filter shuts out oil and water.
- Approved by EN, IEC, and CCC (Chinese standard). (Ground terminal models only.)
- Ground terminal models bear the CE mark.



Model Number Structure

■ Model Number Legend

VB-□□□□□□
1 2 3 4 5 6

1. Number of Plungers

- 2: 2 plungers
- 3: 3 plungers
- 4: 4 plungers
- 5: 5 plungers
- 6: 6 plungers

2. Actuator

- 1: Bevel plunger
- 2: Roller plunger

3. Switch Box

- 1: Flange switch box with two conduit holes on the side
- 2: Flange switch box with four conduit holes
- 4: Non-flange switch box with two conduit holes on the side
- 5: Non-flange switch box with four conduit holes

4. Scraper

- 1: NBR scraper
- 2: FPM scraper

5. Contact

- None: 10 A (standard)
- A: 0.1 A (micro load)

6. Ground Terminal



- None: Without ground terminal
- E: With ground terminal

Replaceable Switch Unit

Rating	Model
Standard load model	VB-S101N

Ordering Information

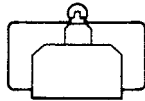
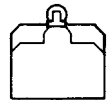
■ List of Models

Actuator	Conduit	Model	
		With flange 	Without flange 
Roller plunger (with a 6.8-dia. roller) 	Two on the side	VB-2211	VB-2241
		VB-3211	VB-3241
		VB-4211	VB-4241
		VB-5211	VB-5241
		VB-6211	VB-6241
	Four	VB-2221	VB-2251
		VB-3221	VB-3251
		VB-4221	VB-4251
		VB-5221	VB-5251
		VB-6221	VB-6251
Bevel plunger 	Two on the side	VB-2111	VB-2141
		VB-3111	VB-3141
		VB-4111	VB-4141
		VB-5111	VB-5141
		VB-6111	VB-6141
	Four	VB-2121	VB-2151
		VB-3121	VB-3151
		VB-4121	VB-4151
		VB-5121	VB-5151
		VB-6121	VB-6151

- Note:**
1. Other than the above models, minute load models switching 0.1 A are available. When ordering a minute load model, add the suffix A to the model number (i.e., VB-2211A for example).
 2. SC connectors can be connected to VB models.
 3. Models with ground terminals are also available. When ordering a ground terminal model, add the suffix E to the model number (i.e., VB-2211E for example).
 4. Since the actuator is incorporated into the monoblock switch, the actuator cannot be replaced.

Specifications

■ Approved Standards

Agency	Standards	File No.	Approved models
TÜV Rheinland	EN60947-5-1 (IEC947-5-1)	R9551017	Only models with ground terminals
CCC (CQC)	GB14048.5	2003010305077628	Ask your OMRON representative for information on approved models.

Note: Ground terminal models only.

■ Approved Standard Ratings

TÜV (EN60947-5-1) (Only Ground Terminal Models are Approved)

Standard Load

Applicable category and ratings
AC-15 2 A/250 VAC
DC-12 2 A/48 VDC

Micro Load

Applicable category and ratings
AC-14 0.1 A/125 VAC
DC-12 0.1 A/30 VDC

CCC (GB14048.5)

Applicable category and ratings
AC-15 2 A/250 VAC

■ General Ratings

Standard Load

Rated voltage	Resistive load		Inrush current	Inrush current
	NC	NO	NC	NO
125 VAC	10 A		24 A max.	
250 VAC	10 A			
125 VDC	0.6 A			
250 VDC	0.3 A			

Note: The above currents are steady-state currents.

Micro Load Ratings

Rated voltage	Resistive load
125 VAC	0.1 A
8 VDC	0.1 A
30 VDC	0.1 A

■ Characteristics

Degree of protection	IP67
Durability (See note 2.)	Mechanical: 5,000,000 operations min. Electrical: 300,000 operations min. (10 A at 250 VAC, resistive load)
Operating speed	0.1 mm to 0.5 m/s
Operating frequency	Mechanical: 120 operations min. Electrical: 30 operations min.
Rated frequency	50/60 Hz (AC)
Insulation resistance	100 MΩ min. (at 500 VDC)
Contact resistance	15 mΩ max. (initial value)
Dielectric strength	1,000 VAC/U _{imp} 4,000 VAC between terminals of same polarity 1,500 VAC/U _{imp} 4,000 VAC between current-carrying metal parts and ground 1,500 VAC/U _{imp} 4,000 VAC between each terminal and non-current-carrying metal part U _{imp} 4 kV (EN60947-5-1) between terminals of different polarity
Rated insulation voltage (U _i)	300 VAC (EN60947-5-1)
Switching overvoltage	1,000 V max. (EN60947-5-1)
Pollution degree (operating environment)	3 (EN60947-5-1)
Short-circuit protective device (SCPD)	10 A fuse type gG or gI (IEC269)
Conditional short-circuit current	100 A (EN60947-5-1)
Conventional enclosed thermal current (I _{the})	5 A, 0.5 A (EN60947-5-1)
Protection against electric shock	Insulation class I (Use the grounding terminal or ground on the machine side.)
Vibration resistance	Malfunction: 10 to 55 Hz, 1.5-mm double amplitude
Shock resistance	Destruction: 1,000 m/s ² min. Malfunction: 200 m/s ² min.
Ambient temperature	Operating: -10°C to 80°C (with no icing)
Ambient humidity	Operating: 95% max.
Weight	Approx. 580 g (in the case of VB-4211)

Note: 1. The above values are initial values.

2. The values are calculated at an operating temperature of 5°C to 35°C, and an operating humidity of 40% to 70%. Contact your OMRON sales representative for more detailed information on other operating environments.

Connections

■ Contact Form

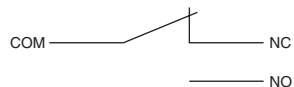

Nomenclature (for the VB-2211)

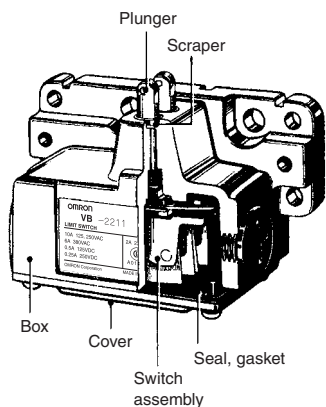

Engineering Data

■ Electrical Durability (with more than 300,000 Operations)

(Ambient temperature: 5°C to 35°C; Ambient humidity: 40% to 70%)

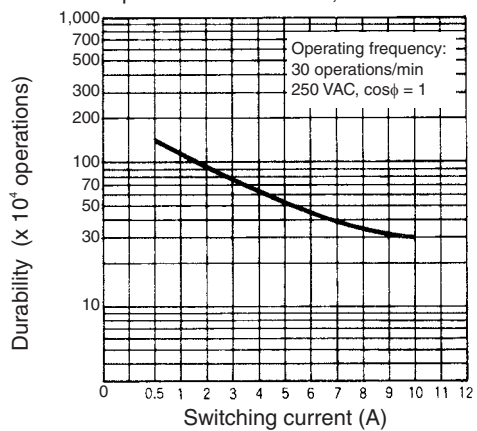

Dimensions

Note: All units are in millimeters unless otherwise indicated.

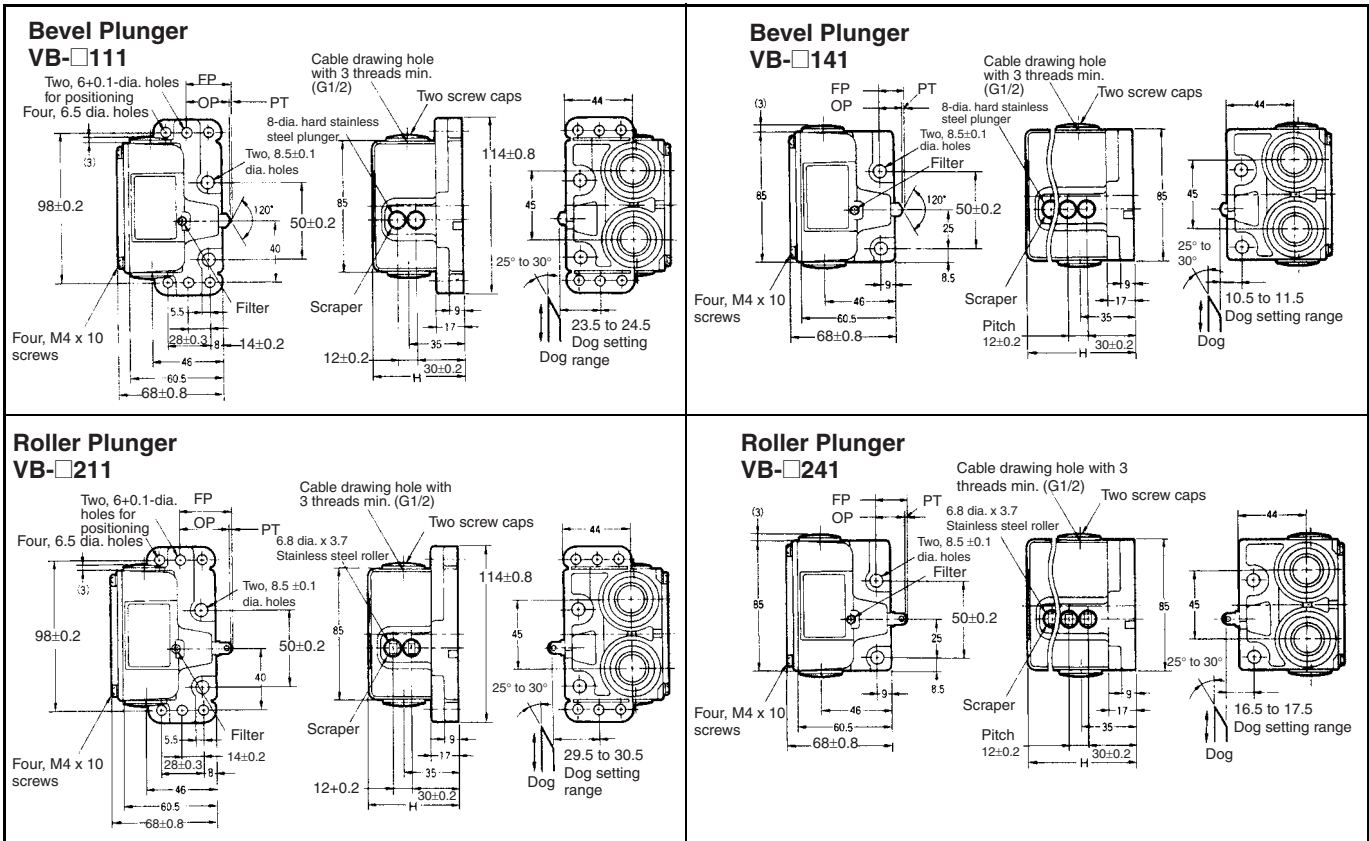

Model	VB-□211	VB-□241	VB-□111	VB-□141
OF max.	14.71 N	14.71 N	14.71 N	14.71 N
RF min.	4.90 N	4.90 N	4.90 N	4.90 N
PT max.	1.5 mm	1.5 mm	1.5 mm	1.5 mm
OT (see note 2)	(3.5 mm)	(3.5 mm)	(3.5 mm)	(3.5 mm)
MD max.	0.5 mm	0.5 mm	0.5 mm	0.5 mm
OP	32±0.4 mm	19±0.4 mm	26±0.4 mm	13±0.4 mm
FP (see note 2)	(33 mm)	(20 mm)	(27 mm)	(14 mm)

- Note: 1. The above operating characteristic values apply to a single switch.
 2. The OT and FP values are reference values.
 3. The actual model numbers of each of the above VB models have a figure 2 to 6, which indicate the number of plungers.

Number of plungers	H
2	58 mm
3	70 mm
4	82 mm
5, 6 (see note)	106 mm

Note: When five plungers are mounted in series, no outer actuator will be provided.

Precautions

Refer to the "Precautions for All Switches" on page 17 and "Precautions for General-purpose Limit Switches (Including Multiple Limit Switches, Mechanical Touch Switches, High-precision Switches, Touch Switches, On-site Flexible Switches; Not Including Safety Switches)" on page 23.

Correct Use

Be sure to connect a fuse with a breaking current 1.5 to 2 times larger than the rated current to the Switch in series in order to protect the Switch from damage due to short-circuiting.

If the VB is used for EN ratings, use a gI or gG 10-A fuse approved by IEC269.

Operation

Make sure the notch of the plunger is not pressed into the scraper when operating the VB Multiple Limit Switch, otherwise chips or dust may penetrate into the VB Multiple Limit Switch.

Sealing

The switch box and cover are made of die-cast aluminum and the mounting part of the Switch is covered with a seal cap, and ensure a sealing performance of more than 98×10^3 Pa for the VB Multiple Limit Switch.

The filter on the side of the head prevents oil and water from penetrating into the interior of the VB Multiple Limit Switch while preventing the internal pressure of the VB Multiple Limit Switch from rising when the plunger is pressed.

The seal scraper on the tip of the actuator prevents chips and dust from penetrating into the moving parts of the VB Multiple Limit Switch.

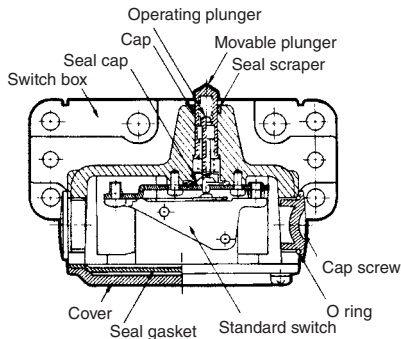

Apply extra tightening to the cap screw on the conduit.

In order to protect the plunger from abrasion and prolong its service life, apply a small amount of grease to the plunger and dog or cam that come into contact with the plunger. (Molybdenum disulfide grease is recommended.)

Tightening Torque

1. Tighten each cover mounting screw to a torque of 1.18 to 1.37 N·m.
2. Tighten each switch terminal screw to a torque of 0.20 to 0.49 N·m if the mounting screw is M3 in size.

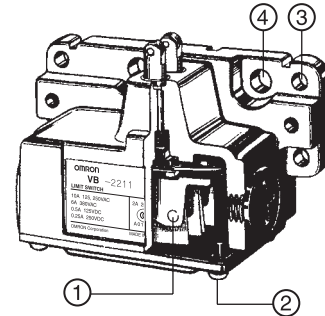

Be sure to wire each solderless terminal correctly with a screw as shown below.

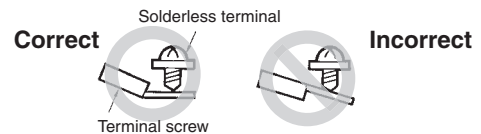

3. Apply a torque of 5.88 to 6.86 N·m to tighten each mounting bolt of the casing if the mounting bolt is an Allen-head bolt that is M6 in size. Apply a torque of 8.04 to 9.22 N·m instead if the mounting bolt is an Allen-head bolt that is M8 in size.

Mounting

Mounting Holes

With a Flange Switch Box

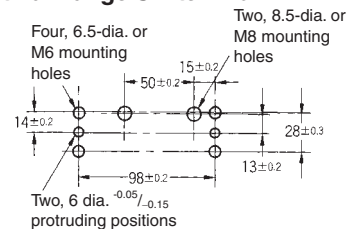

Without a Flange Switch Box

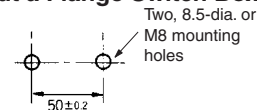

Wiring

Connect a cable with a thickness of 0.75 mm² to the VB Multiple Limit Switch through the M3 round solderless terminals with insulation covers.

Dimensions of Round Solderless Terminal

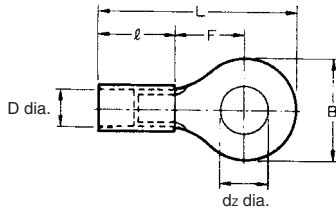

dz dia.:	3.2
D dia.:	1.9
B:	5.2
L:	16.4
F:	5.8
l:	8.0 (mm)

Wiring (Ground Terminal Models)

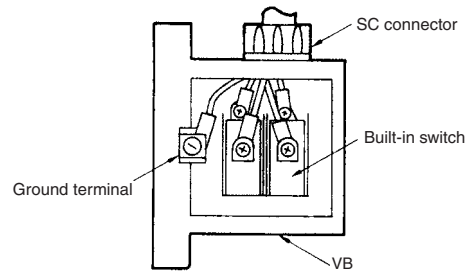

Note: Consult your OMRON representative for details on models with 3 to 6 plungers.

Others

Carefully connect a conduit to each conduit hole and apply a seal or tape to seal the conduit hole so that cuttings or other materials will not penetrate through the conduit hole.

Use the SC Connector. Consult your OMRON representative for details on SC Connectors.

Make sure that the position of the actuator that is traveling does not exceed the overtravel (OT) position.

Make sure that the operating stroke is 70% to 100% of the specified OT distance.

ALL DIMENSIONS SHOWN ARE IN MILLIMETERS.

To convert millimeters into inches, multiply by 0.03937. To convert grams into ounces, multiply by 0.03527.