

Touch Switch D5C

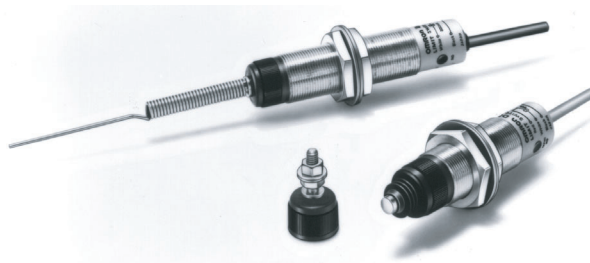

Unique 18-mm-dia. Capacitive Touch Switch with Choice of Three Actuators is Activated with Only a Very Slight Physical Contact

- Lightweight objects, such as thin wire or foil can be accurately detected.
- Solid-state switch activates the moment its actuator comes in contact with the object.
- Amplifier, operation indicator, and sensitivity adjuster are built-in on all models.
- Conforms to IEC IP67 and NEMA Type 6, 6P.
- Actuators can be freely interchanged between switch units.
- A unique free-attachment version allows any kind of actuator antenna to be attached.



Ordering Information

■ List of Models

Features		Usable by bending tip of antenna. Overtravel of 20 mm max.	Ideal for high-accuracy position control. Overtravel of 3.5 mm max.	Any actuator can be attached.
Cable		3 m		
Actuator		Coil spring 	Plunger 	Free-attachment 
Power source	DC	D5C-1DS0	D5C-1DP0	D5C-1DA0
	AC	D5C-1AS0	D5C-1AP0	D5C-1AA0
Antenna only		D5C-00S0	D5C-00P0	D5C-00A0

Specifications

■ Characteristics

Model	DC		AC
	D5C-1D□0		D5C-1A□0
Degree of protection	Equivalent to IP67 (NEMA 6, 6P)		
Durability	Mechanical: 10,000,000 operations min. (at rated overtravel value)		
Supply voltage (operating voltage)	12 to 24 VDC (10 to 30 VDC), (ripple: 10% max.)		100 to 240 VAC (45 to 264 VAC), 50/60 Hz
Rated frequency	---		50/60 Hz
Sensitivity setting range	30 to 100 pF		
Current consumption	17 mA max.		---
Leakage current	Circuit: --- Antenna: 1 mA max.		Circuit: 2 mA max. Antenna: 1 mA max.
Response time	2 ms max.		8 ms max.
Output current	200 mA max. (resistive load)		
Insulation resistance	50 MΩ min. (at 500 VDC) between lead wires and case		

Model	DC	AC
	D5C-1D□□0	D5C-1A□□0
Dielectric strength	1,000 VAC, 50/60 Hz for 1 min between current-carrying metal parts and non-current-carrying metal parts	2,000 VAC, 50/60 Hz for 1 min between current-carrying metal parts and non-current-carrying metal parts
Rated insulation voltage (U _i)	1,000 VAC	
Pollution degree (operating environment)	Level 3 (IEC947-5-1)	
Protection against electric shock	Class II	
Proof tracking index (PTI)	175	
Switch category	D (IEC335)	
Vibration resistance	10 to 55 Hz, 1.5-mm double amplitude	
Shock resistance	1,000 m/s ² min.	
Ambient temperature	Operating: -25°C to 70°C (with no icing)	
Ambient humidity	95% max.	
Weight	Approx. 110 g (in case of D5C-1DSO)	Approx. 120 g (in case of D5C-1ASO)

Output Circuit

D5C-1D□□0 (DC Model)

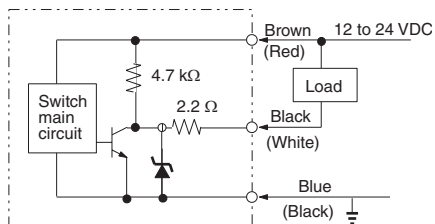

D5C-1A□□0 (AC Model)

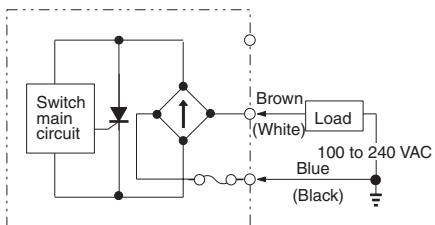

Note: Color in () denotes the old model.

Nomenclature

D5C-1DS0

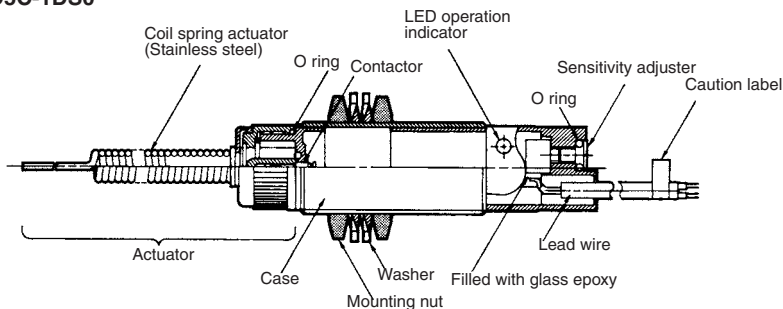

Engineering Data

Typical Examples

Temperature Characteristics of DC Models

D5C-1D□0 (24 VDC)

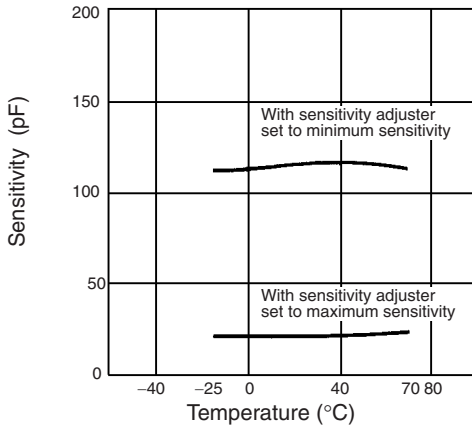

Temperature Characteristics of AC Models

D5C-1A□0 (100 VAC)

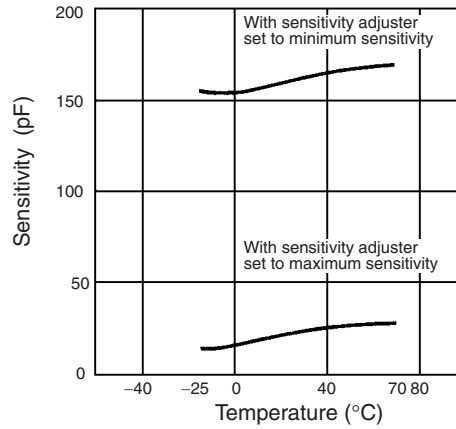

Voltage Characteristics of DC Model

D5C-1D□0 (at 25°C)

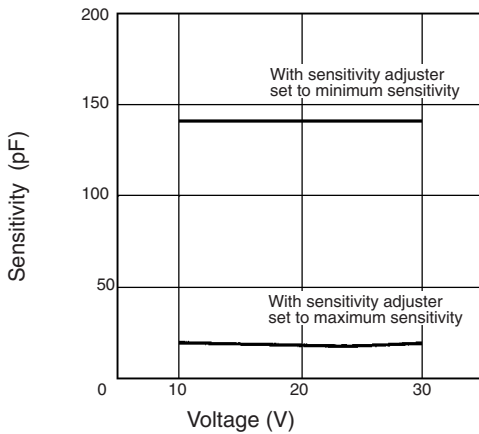

Voltage Characteristics of AC Model

D5C-1A□0 (at 25°C)

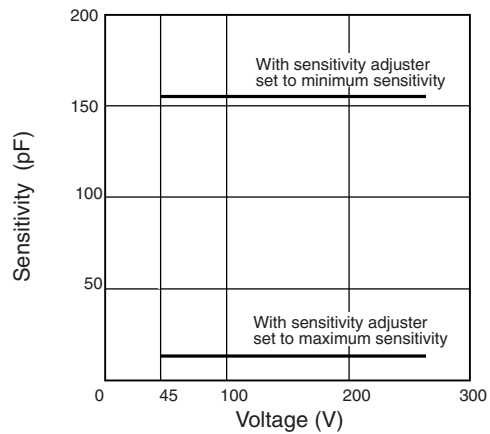

Application Examples

Detection of Incorrectly Set Work

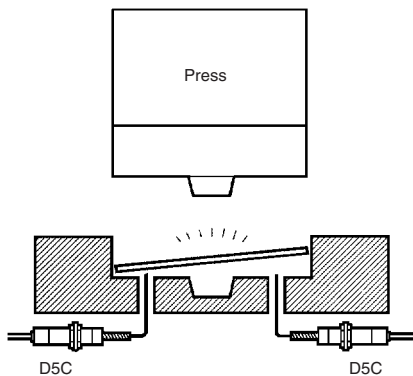

Detection of Fine Wire or Thin Plate

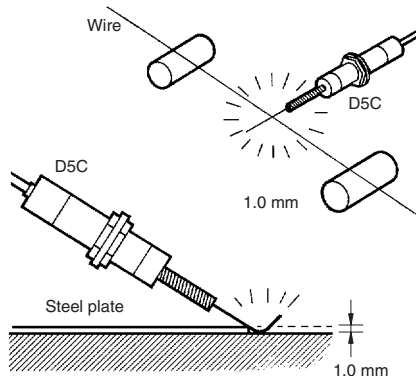

Detection of Loose Screws

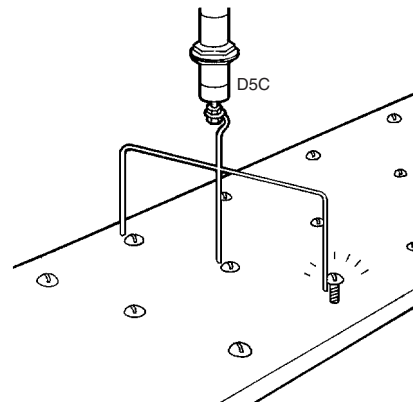

Precautions

Refer to the "Precautions for All Switches" on page 17 and "Precautions for General-purpose Limit Switches (Including Multiple Limit Switches, Mechanical Touch Switches, High-precision Switches, Touch Switches, On-site Flexible Switches; Not Including Safety Switches)" on page 23.

CAUTION

Make sure that the antenna does not come into contact with the human body, otherwise an electric shock may be received.



tance between the sensing object and the ground is, the higher the capacitance will be. Furthermore, the capacitance greatly varies with the ground condition (e.g., dry sand, concrete, or wet soil).

Contact with Non-grounded Conductor

The sensing object is equivalently grounded through capacitor C.

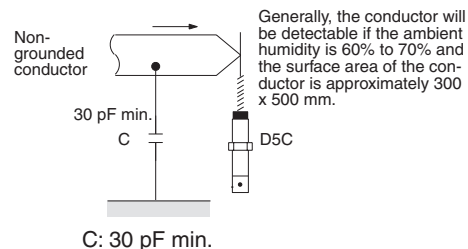

Correct Use

Grounding of Antenna and Sensing Object (Size of Sensing Object)

Grounded Object

If the sensing object is the following grounded conductor, its size will not affect the operation of the D5C. Check for the presence of insulators sticking to the sensing object or the corrosion of the sensing object, however, so that the ground resistance will not exceed 3 kΩ.

Contact with Grounded Conductor

The sensing object is equivalently grounded through ground resistor R.

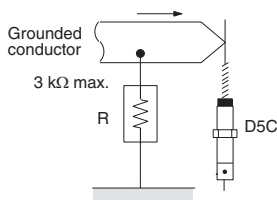

R: 3 kΩ max.
The sensing object must not come into contact with the human body.

Conditions of Sensing Object

The detection of conductors (e.g., iron, stainless steel, aluminum, and brass objects) poses no particular problem. A conductor coated with paint cannot be detected, however, because there is no electrical continuity between the antenna and the conductor.

Non-conductive objects (e.g., plastic, ceramic, glass, and cloth objects) can be detected by grounding them indirectly.

Antenna

Shape and Extension

If a metal plate is used as an antenna by connecting it to the built-in or separated antenna of the D5C, the surface area of the metal plate must be 200 cm² maximum (Fig. 1). The antenna can be extended, provided that the total length of the antenna is 1 m maximum (Fig. 2) and that the bottom of the antenna is at least 10 cm (Fig. 3) away from the ground. Refer to the illustrations below.

The D5C may be damaged if the antenna is excessively large or heavy or if the antenna is used in locations with excessive vibration or shock. Be sure to check the locations before use.

Non-grounded Object

If the sensing object is the following non-grounded conductor, the D5C will operate if the capacitance between the sensing object and the ground is 30 pF or more. The larger the surface area of the sensing object is, the higher its capacitance will be. The shorter the dis-

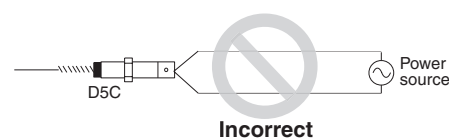
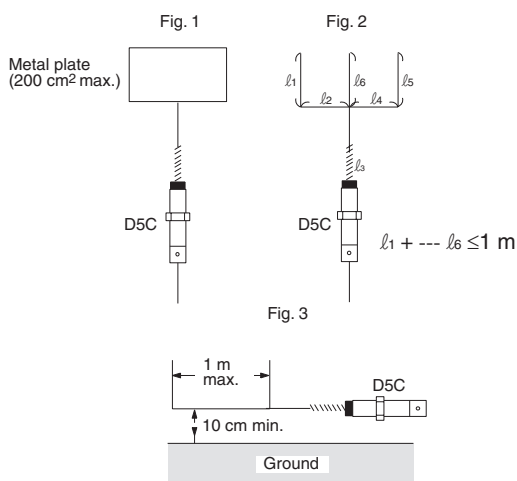

Incorrect

If there are wire power lines or high-tension lines close to the cord of the D5C, be sure to wire the cord of the D5C away from power lines or high-tension lines or lay the cord in an exclusive, shielded conduit. Remove the caution label on the end of the cord before wiring the cord.

D5C-1A□0 (AC Models)

Be aware that the D5C-1A□0 not in operation has a leakage current of approximately 2 mA. Especially, if the load is a relay with a current flow of 10 mA or less, a reset failure may result due to the residual voltage. Therefore, connect a bleeder resistor as shown below so that the residual voltage will be less than the reset voltage of the load.

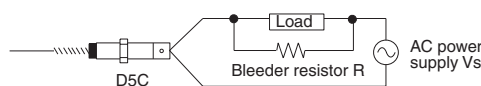

The bleeder resistance and permissible power are obtained from the following formula.

$$R \leq V_S / (10 - I) \text{ (k}\Omega\text{)}$$

$$P > V_S^2 / R \text{ (mW)}$$

P: W number of bleeder load

P: Withstanding power of bleeder resistor

(Practically, the wattage must be a few times larger than the obtainable value.)

I: Load current (mA)

If a DC relay or DC counter is used as a load connected through an electronic timer or current rectification circuit, pay the utmost attention so that the leakage current of the D5C AC model will not cause the load to malfunction.

Sensitivity Adjustment

The sensitivity of the D5C can be adjusted by turning the adjuster on the rear side with a flat-blade screwdriver.

The sensitivity increases by turning the adjuster clockwise and decreases by turning the adjuster counterclockwise.

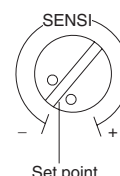

Be sure to turn the adjuster with a torque of 4.9 to 7.8 mN • m. If excessive torque is applied, the adjuster will break.

Parallel Arrangement

If there are multiple D5Cs are located in parallel, make sure that the distance between adjacent antennas is at least 3 cm.

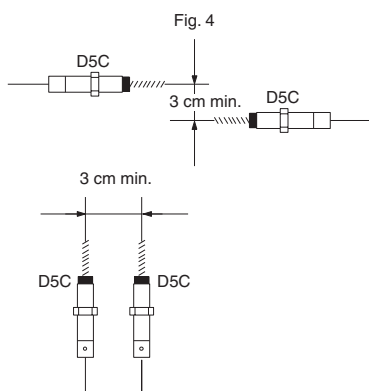

Maintenance

Make sure that the portion of the antenna that comes into contact with sensing objects is free of oil, dirt, or rust, or any other insulator. Otherwise, the D5C will not operate.

The degree of protection of the D5C is IP67. The D5C cannot be, however, used in the water or oil.

Locations with Sprayed Water or Oil

The D5C may malfunction in locations where the D5C is frequently exposed to sprayed water or oil. Especially, the D5C may malfunction more frequently if it is exposed to sprayed water-soluble cutting oil. In such locations, be sure to take appropriate measures to protect the D5C from oil and water.

Wiring and Connections

Be sure to wire the D5C correctly according to the color of each cord. Incorrect wiring may damage the internal components of the D5C or the D5C may malfunction.

If AC models are connected in parallel, make sure that a load is connected to each of the models.

A maximum of two models can be connected in series provided that 100 to 240 V is supplied. DC models cannot be connected in series.

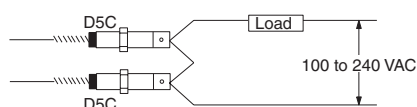

Be sure to supply power to the D5C via the load. If power is supplied to the D5C directly, the fuse will blow.

Grounding

In order to maintain the operational reliability of the D5C, be sure to ground the blue or black wire of the power cord.

The service power supply of the PC (Programmable Controller) is not available to the D5C-1D□0. The negative line of the service power supply of the PC is not grounded. Therefore, the D5C may not operate.

Furthermore, if the negative line of the service power supply is grounded, the noise resistance of the PC will drop.

Provided that single-phase 200 V is supplied to the D5C-1A□0, if one phase is grounded, the power supply will be short-circuited and a machinery breakdown will result. Use an isolating transformer and ground the secondary side of the transformer instead.

In the above case, be sure to ground the secondary side, otherwise the D5C may not operate.



The lead wire colors of the D5C have been changed in compliance with the latest applicable JIS standards. Colors in parentheses are previous ones.

Mounting

Do not tighten the nuts with excessive force. The maximum permissible tightening force of each nut with a washer is 29.4 N • m.

Mounting Hole Dimension

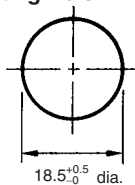

Others

Do not disassemble the D5C, otherwise the internal wiring will be damaged and the D5C will fail to operate.

The sealing of the D5C uses nitrile butadiene rubber (NBR), which is highly oil resistive. If exposed to some types of oil or chemical indoors or outdoors, however, the NBR may deteriorate. Contact your OMRON representative for details.

When mounting the antenna to the D5C, be sure to tighten the antenna to a torque of 0.39 to 0.83 N·m. If the antenna is not tightened securely, the built-in contact may break.

If an appropriate antenna is mounted to a free attachment model, hold the nut on the outer side with a wrench so that the nut will not move. Then tighten the nut on the inner side within a torque range of 0.78 and 1.18 N·m.

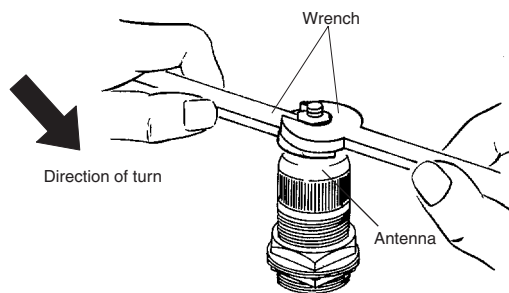

ALL DIMENSIONS SHOWN ARE IN MILLIMETERS.

To convert millimeters into inches, multiply by 0.03937. To convert grams into ounces, multiply by 0.03527.