

Small, Economical Switch Featuring a Positive Opening Mechanism and Conforming to the CE Mark

- Features positive opening mechanism (NC contacts only) that opens contacts, thus preventing faulty operation due to factors such as metal deposition. (Slow-action type has received positive opening approval.)
- Double insulation makes ground terminal unnecessary. (Bears □ marking.)
- Conforms to EN (TÜV) standards corresponding to the CE mark.
- Wide standard operating temperature range: -30°C to 70°C.
- Series expanded to include 2-conduit type and 4 actuator types: cat whisker, plastic rod, metal lever, and fork lever lock.
- Safety Standards:
 - Conformity:
 - Machinery Directive
 - Low Voltage Directive
 - EN50047
 - EN1088

Approved Standards

Snap-action Models

Agency	Standard	File No.
TÜV Rheinland	EN60947-5-1	J9950233 (Positive opening approved.)
UL	UL508 CSA C22.2 No. 14	E76675

Note: CSA C22.2 No. 14 compliance was verified and approved by UL (Marked with .



Slow-action Models

Agency	Standard	File No.
TÜV Rheinland	EN60947-5-1 EN81 EN115	R9451184 (Positive opening approved.)
UL	UL508 CSA C22.2 No. 14	E76675
BIA*	GS-ET-15	1-conduit type: 9407070 2-conduit type: 9601732
SUVA*	SUVA	1-conduit type: E6192.d 2-conduit type E6193.d

Note: *Not including variable roller lever, cat whisker, or plastic rod types.

Ordering Information

■ Model Number Legend

D4D-□□□□N
 1 2 3

1. Conduit

- 1: Pg13.5 (1-conduit)
- 2: G1/2 (1-conduit)
- 3: 1/2-14NPT (1-conduit)
- 5: Pg13.5 (2-conduit)
- 6: G1/2 (2-conduit)

2. Built-in Switch







- 1: 1NC/1NO (Snap-action)
- 5: 1NC/1NO (Slow-action)
- A: 2NC (Slow-action)







3. Head and Actuator

- 20: Roller lever (standard, resin lever)
- 21: Adjustable roller lever
- 22: Roller lever (metal lever)
- 27: Adjustable roller lever (with 50 dia. rubber roller)
- 31: Top plunger
- 32: Top roller plunger
- 62: One-way roller arm lever (horizontal)
- 72: One-way roller arm lever (vertical)
- 80: Cat whisker
- 87: Plastic rod
- RE: Fork lever lock (right operation)
- LE: Fork lever lock (left operation)

■ List of Models

Standard Switch

Actuator	Conduit size (see note 1)		Built-in switch mechanism								
			1NC/1NO (Snap-action)		1NC/1NO (Slow-action)		2NC (Slow-action)				
			Positive opening	Model (see note 2)	Positive opening	Model	Positive opening	Model			
Roller lever (resin lever) 	1-conduit	Pg13.5	⊙	D4D-1120N	⊙	D4D-1520N	⊙	D4D-1A20N			
		G1/2							D4D-2120N	D4D-2520N	D4D-2A20N
		1/2-14NPT							D4D-3120N	D4D-3520N	D4D-3A20N
	2-conduit	Pg13.5							D4D-5120N	D4D-5520N	D4D-5A20N
		G1/2							D4D-6120N	D4D-6520N	D4D-6A20N
Roller lever (metal lever) 	1-conduit	Pg13.5	⊙	D4D-1122N	⊙	D4D-1522N	⊙	D4D-1A22N			
		G1/2							D4D-2122N	D4D-2522N	D4D-2A22N
		1/2-14NPT							D4D-3122N	D4D-3522N	D4D-3A22N
	2-conduit	Pg13.5							D4D-5122N	D4D-5522N	D4D-5A22N
		G1/2							D4D-6122N	D4D-6522N	D4D-6A22N
Adjustable roller lever 	1-conduit	Pg13.5	---	D4D-1121N	⊙ (See note 3)	D4D-1521N	⊙ (See note 3)	D4D-1A21N			
		G1/2							D4D-2121N	D4D-2521N	D4D-2A21N
		1/2-14NPT							D4D-3121N	D4D-3521N	D4D-3A21N
	2-conduit	Pg13.5							D4D-5121N	D4D-5521N	D4D-5A21N
		G1/2							D4D-6121N	D4D-6521N	D4D-6A21N
Adjustable roller lever (with rubber roller) 	1-conduit	Pg13.5	⊙ (See note 3)	D4D-1127N	⊙ (See note 3)	D4D-1527N	⊙ (See note 3)	D4D-1A27N			
		G1/2							D4D-2127N	D4D-2527N	D4D-2A27N
		1/2-14NPT							D4D-3127N	D4D-3527N	D4D-3A27N
	2-conduit	Pg13.5							D4D-5127N	D4D-5527N	D4D-5A27N
		G1/2							D4D-6127N	D4D-6527N	D4D-6A27N
Plunger 	1-conduit	Pg13.5	⊙	D4D-1131N	⊙	D4D-1531N	⊙	D4D-1A31N			
		G1/2							D4D-2131N	D4D-2531N	D4D-2A31N
		1/2-14NPT							D4D-3131N	D4D-3531N	D4D-3A31N
	2-conduit	Pg13.5							D4D-5131N	D4D-5531N	D4D-5A31N
		G1/2							D4D-6131N	D4D-6531N	D4D-6A31N
Roller plunger 	1-conduit	Pg13.5	⊙	D4D-1132N	⊙	D4D-1532N	⊙	D4D-1A32N			
		G1/2							D4D-2132N	D4D-2532N	D4D-2A32N
		1/2-14NPT							D4D-3132N	D4D-3532N	D4D-3A32N
	2-conduit	Pg13.5							D4D-5132N	D4D-5532N	D4D-5A32N
		G1/2							D4D-6132N	D4D-6532N	D4D-6A32N

Actuator	Conduit size (see note 1)		Built-in switch mechanism					
			1NC/1NO (Snap-action)		1NC/1NO (Slow-action)		2NC (Slow-action)	
			Positive opening	Model (see note 2)	Positive opening	Model	Positive opening	Model
One-way roller arm lever (horizontal) 	1-conduit	Pg13.5	⊙	D4D-1162N	⊙	D4D-1562N	⊙	D4D-1A62N
		G1/2		D4D-2162N		D4D-2562N		D4D-2A62N
		1/2-14NPT		D4D-3162N		D4D-3562N		D4D-3A62N
	2-conduit	Pg13.5		D4D-5162N		D4D-5562N		D4D-5A62N
		G1/2		D4D-6162N		D4D-6562N		D4D-6A62N
One-way roller arm lever (vertical) 	1-conduit	Pg13.5	⊙	D4D-1172N	⊙	D4D-1572N	⊙	D4D-1A72N
		G1/2		D4D-2172N		D4D-2572N		D4D-2A72N
		1/2-14NPT		D4D-3172N		D4D-3572N		D4D-3A72N
	2-conduit	Pg13.5		D4D-5172N		D4D-5572N		D4D-5A72N
		G1/2		D4D-6172N		D4D-6572N		D4D-6A72N
Fork lever lock (right operation) (See note 4) 	1-conduit	Pg13.5	---	---	⊙ (See note 3)	D4D-15REN	⊙ (See note 3)	D4D-1AREN
		G1/2				D4D-25REN		D4D-2AREN
		1/2-14NPT				D4D-35REN		D4D-3AREN
	2-conduit	Pg13.5				D4D-55REN		D4D-5AREN
		G1/2				D4D-65REN		D4D-6AREN
Fork lever lock (left operation) (See note 4) 	1-conduit	Pg13.5	---	---	⊙ (See note 3)	D4D-15LEN	⊙ (See note 3)	D4D-1ALEN
		G1/2				D4D-25LEN		D4D-2ALEN
		1/2-14NPT				D4D-35LEN		D4D-3ALEN
	2-conduit	Pg13.5				D4D-55LEN		D4D-5ALEN
		G1/2				D4D-65LEN		D4D-6ALEN
Cat whisker 	1-conduit	Pg13.5	---	D4D-1180N	---	---	---	D4D-1A80N
		G1/2		D4D-2180N		---		D4D-2A80N
		1/2-14NPT		D4D-3180N		---		D4D-3A80N
	2-conduit	Pg13.5		D4D-5180N		---		D4D-5A80N
		G1/2		D4D-6180N		---		D4D-6A80N
Plastic rod 	1-conduit	Pg13.5	---	D4D-1187N	---	---	---	D4D-1A87N
		G1/2		D4D-2187N		---		D4D-2A87N
		1/2-14NPT		D4D-3187N		---		D4D-3A87N
	2-conduit	Pg13.5		D4D-5187N		---		D4D-5A87N
		G1/2		D4D-6187N		---		D4D-6A87N

- Note:**
1. It is recommended that Pg13.5 be used for Switches to be exported to Europe and 1/2-14NPT be used for Switches to be exported to North American countries.
 2. Adjustable rod lever actuators for snap-action models (model number: D4D-□□29N) are available separately.
 3. The switches are marked with "⊙" indicating approval by TÜV Rheinland for the positive opening mechanism. Adjustable roller lever and fork lever lock models are approved by TÜV Rheinland for the positive opening mechanism, but not by the GS-ET-15 standard (BIA) nor by SUVA.
 4. Right operation: Contact 11-12 is positively opened, when the lever on the right is lowered.
Left operation: Contact 11-12 is positively opened, when the lever on the left is lowered.

Specifications

■ Approved Standard Ratings TÜV (EN60947-5-1)

Utilization category	AC-15
Rated operating current (I_{θ})	2 A
Rated operating voltage (U_{θ})	400 V

Note: As protection against short-circuiting, use either a gI-type or gG-type 10-A fuse that conforms to IEC269.

**UL/CSA (UL508/CSA C22.2 No. 14)
A600 (D4D-□5□□N, D4D-□A□□N)**

Type	Rated voltage	Carry current	Current		Volt-amperes	
			Make	Break	Make	Break
Slow-action	120 VAC 240 VAC 480 VAC 600 VAC	10 A	60 A 30 A 15 A 7.5 A 12 A	6 A 3 A 1.5 A 1.2 A	7,200 VA	720 VA

B600 (D4D-□1□□N)

Type	Rated voltage	Carry current	Current		Volt-amperes	
			Make	Break	Make	Break
Snap-action	120 VAC 240 VAC 480 VAC 600 VAC	5 A	30 A 15 A 7.5 A 6 A	3 A 1.5 A 0.75 A 0.6 A	3,600 VA	360 VA

■ Characteristics

Degree of protection	IP65 (EN60947-5-1)
Life expectancy (see note 2)	Mechanical: 15,000,000 operations min. (see note 3) Electrical: 150,000 operations min. (Refer to <i>Operating Characteristics</i> for snap-action.)
Operating speed	1 mm/s to 0.5 m/s (with D4D-1120N)
Contact gap	Snap-action: 2 x 0.5 mm min. Slow-action: 2 x 2 mm min.
Operating frequency	Mechanical: 120 operations/min min. Electrical: 30 operations/min min.
Rated frequency	50/60 Hz
Insulation resistance	100 MΩ min. (at 500 VDC) between terminals of the same polarity and between each terminal and non-current-carrying metal parts
Contact resistance	25 mΩ max. (initial value)
Dielectric strength	Snap-action U _{imp} 2.5 kV between terminals of the same polarity U _{imp} 4 kV between each terminal and non-current-carrying metal parts Slow-action U _{imp} 4 kV between terminals of the same polarity, between terminals of different polarity, and between each terminal and non-current-carrying metal parts
Rated insulation voltage (U _i)	400 V (EN60947-5-1)
Switching overvoltage	1,500 V max. (EN60947-5-1)
Pollution degree (operating environment)	3 (EN60947-5-1)
Short-circuit protective device (SCPD)	10 A, fuse type gI or gG (IEC269)
Conditional short-circuit current	100 A (EN60947-5-1)
Conventional enclosed thermal current (I _{the})	10 A (EN60947-5-1)
Protection against electric shock	Class II (double insulation)
Vibration resistance	Malfunction: 10 to 55 Hz, 0.75-mm single amplitude
Shock resistance	Destruction: 1,000 m/s ² min. Malfunction: 300 m/s ² min.
Ambient temperature	Operating: -30°C to 70°C (with no icing)
Ambient humidity	Operating: 95% max.
Weight	Approx. 70 g (for D4D-1120N) Approx. 86 g (for D4D-5120N)

- Note:**
- The above figures are initial values.
 - Life expectancy values are calculated at an operating temperature of 5 to 35°C, and an operating humidity of 40 to 70%. Contact your OMRON sales representative for more detailed information on other operating environments.
 - The mechanical life expectancy of the fork lever lock model is 10,000,000 operations min.

■ Operating Characteristics

Snap-action (1NC/1NO), Slow-action (2NC)

1-conduit and 2-conduit Models

Model	D4D-□120N D4D-□A20N	D4D-□121N D4D-□A21N (see note 1)	D4D-□122N D4D-□A22N	D4D-□127N D4D-□A27N (see note 2)	D4D-□131N D4D-□A31N	D4D-□132N D4D-□A32N	D4D-□162N D4D-□A62N	D4D-□172N D4D-□A72N	D4D-□180N D4D-□A80N	D4D-□187N D4D-□A87N
OF max.	4.90 N	4.22 N	4.90 N	4.22 N	6.37 N		3.92 N	4.41 N	1.47 N	
RF min.	0.49 N	0.42 N	0.49 N	0.42 N	1.47 N		0.78 N	0.88 N	---	
PT	18° to 27°				2 mm max.		4 mm max.		15° max.	
OT min.	40°				4 mm		5 mm		---	
MD max. (see note 3)	14°				1 mm	1 mm	1.5 mm		---	
OP	---				18.2±0.5 mm	28.2±0.8 mm	37±0.8 mm	27±0.8 mm	---	
TT (see note 4)	(70°)				(6 mm)		(9 mm)		---	
POT min. (see note 5)	50°				3.2 mm		5.8 mm	4.8 mm	---	
POF min. (see note 5)	19.61 N				19.61 N		---		---	

- Note:**
1. The operating characteristics of these switches were measured with the roller lever set at 30 mm.
 2. The operating characteristics of these switches were measured with the roller lever set at 31 mm.
 3. Only for snap-action models.
 4. Nominal value.
 5. Only for slow-action models. POT (positive opening travel) and POF (positive opening force) are required values for positive opening.

Slow-action (1NC/1NO)

1-conduit and 2-conduit Models

Model	D4D-□520N	D4D-□521N (see note 1)	D4D-□522N	D4D-□527N (see note 2)	D4D-□531N	D4D-□532N	D4D-□562N	D4D-□572N
OF max.	4.90 N	4.22 N	4.90 N	4.22 N	6.37 N		3.92 N	4.41 N
RF min.	0.49 N	0.42 N	0.49 N	0.42 N	1.47 N		0.78 N	0.88 N
PT (see note 3)	18° to 27°				2 mm max.		4 mm max.	
PT (2nd) (see note 4)	(44°)				(2.9 mm)		(5.2 mm)	(4.3 mm)
OT min.	40°				4 mm		5 mm	
OP	---				18±0.5 mm	28.2±0.8 mm	37±0.8 mm	27±0.8 mm
TT (see note 5)	(70°)				(6 mm)		(9 mm)	
POT min. (see note 6)	50°				3.2 mm		5.8 mm	4.8 mm
POF min. (see note 6)	19.61 N				19.61 N		---	

- Note:**
1. The operating characteristics of these Switches were measured with the roller lever set at 30 mm.
 2. The operating characteristics of these Switches were measured with the roller lever set at 31 mm.
 3. Measured with NC side in the OFF state.
 4. PT (2nd) is the distance required before NO contact occurs.
PT (2nd) is the reference value.
 5. Nominal value.
 6. POT (positive opening travel) and POF (positive opening force) are required values for positive opening.

Slow-action (1NC/1NO), Slow-action (2NC)

1-conduit and 2-conduit Models

Model	D4D-□□REN	D4D-□□LEN
Force necessary to reverse the direction of the lever: max.	6.37 N	
Movement until the lever reverses	45° to 65°	
Movement until switch operation (NC)	(6.5°)	
Movement until switch operation (NO)	(18.5°)	
POT min.	30°	
POF min.	19.61 N	

- Note:** POT (positive opening travel) and POF (positive opening force) are required values for positive opening.

Engineering Data

Electrical Life Expectancy (1NC/1NO Contact, Snap-action)

($\cos\phi = 1$)

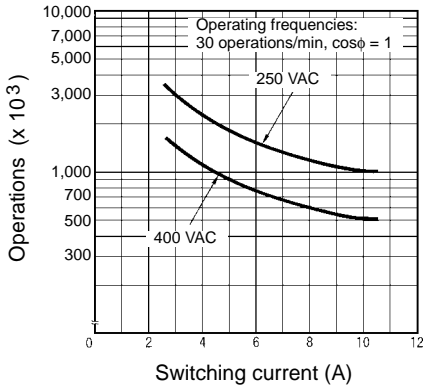

($\cos\phi = 0.4$)

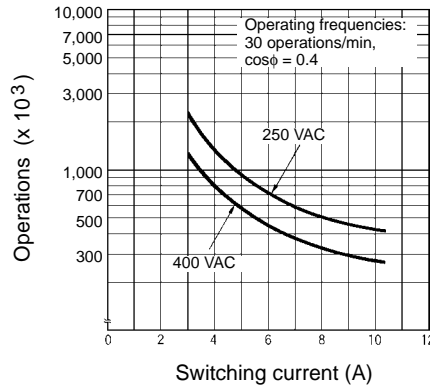

Nomenclature

Head

With Roller Lever Switches, the direction of the switch head can be varied to any of the four directions by loosening the roller lever switch screws at the four corners of the head.

Built-in Switch

Wide switch variations.
 Snap-action: 1NC/1NO
 Slow-action: 1NC/1NO
 2NC

Conduit Opening

Available in two different types of conduit threads:
 Pg 13.5: European standard (1-conduit, 2-conduit)
 G 1/2: Japanese standard (1-conduit, 2-conduit)
 1/2-14NPT: US standard (1-conduit)

Conduit Cap

Can be used as a simple connector under good environmental conditions.

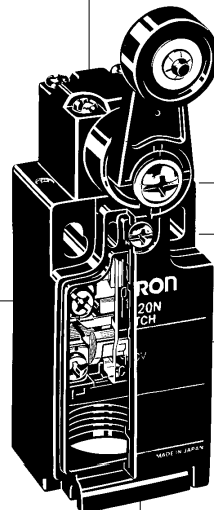

Safety-oriented Lever Setting

Grooves which engage the lever every 90° are cut in the operation indicator disk to prevent the lever from slipping against the rotary shaft. There are resin-lever and metal-lever types.

Cover

Easy to open and wire. (One mounting screw and opposite side is for hinge mounting.)

Contact Material

Ag alloy

Operation

■ Positive Opening Mechanism

1NC/1NO Contact (Snap-action)

Conforms to EN60947-5-1 Positive Opening 

If metal deposition between mating contacts occurs on the NC contact side, they can be pulled apart by the shearing force and tensile force generated when part B of the safety cam or plunger engages part A of the movable contact blade. When the safety cam or plunger is moved in the direction of the black arrow, the Limit Switch releases.

1. When metal deposition occurs.

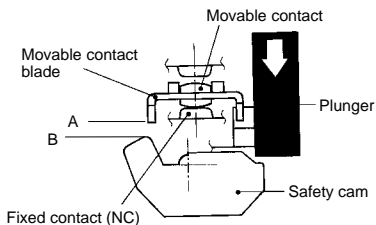

2. When contacts are being pulled apart.

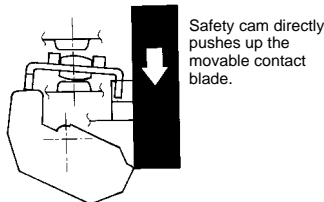

3. When contacts are completely pulled apart.

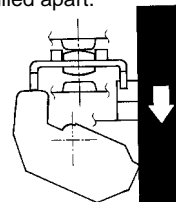

1NC/1NO Contact (Slow-action)

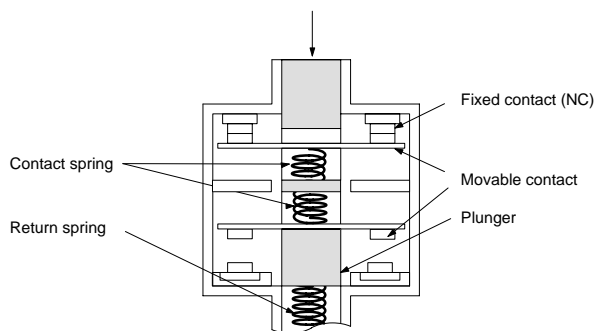

Conforms to EN60947-5-1 Positive Opening 

When metal deposition occurs, the contacts are separated from each other by the plunger being pushed in.

2NC Contact (Slow-action)

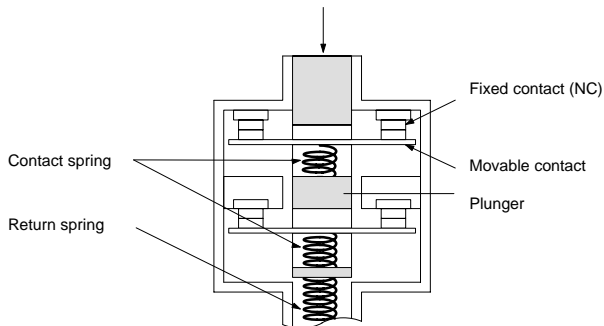

Conforms to EN60947-5-1 Positive Opening 

When metal deposition occurs, the contacts are separated from each other by the plunger being pushed in.

■ Contact Form (EN60947-5-1, EN50013)

Model	Contact type	Contact	Diagrams (see note)	Remarks
D4D-□1□N	1NC/1NO (snap-action)			<p>Only NC contact 11-12 has an approved positive opening mechanism. →</p> <p>Terminal numbers 11-12 and 13-14 cannot be used as unlike poles.</p>
D4D-□5□N	1NC/1NO (slow-action)			<p>Only NC contact 11-12 has an approved positive opening mechanism. →</p> <p>Terminal numbers 11-12 and 23-24 can be used as unlike poles.</p>
D4D-□A□N	2NC (slow-action)			<p>Both NC contacts 11-12 and 23-24 have an approved positive opening mechanism. →</p> <p>Terminal numbers 11-12 and 21-22 can be used as unlike poles.</p>

Note: 1. Contact operation

Closed Open

2. Terminal numbers are assigned according to EN50013 and the contact symbols are assigned according to the IEC947-5-1.

Dimensions

■ 1-conduit Models

- Note:**
- All units are in millimeters unless otherwise indicated.
 - Unless otherwise specified, a tolerance of ± 0.4 mm applies to all dimensions.
 - When placing your order, specify the conduit type by adding a code from the list below to the blank box of the following model numbers as shown below.
 - PG 13.5
 - G 1/2
 - 1/2-14NPT

Roller Lever (Resin Lever)

D4D-□120N

D4D-□520N

D4D-□A20N

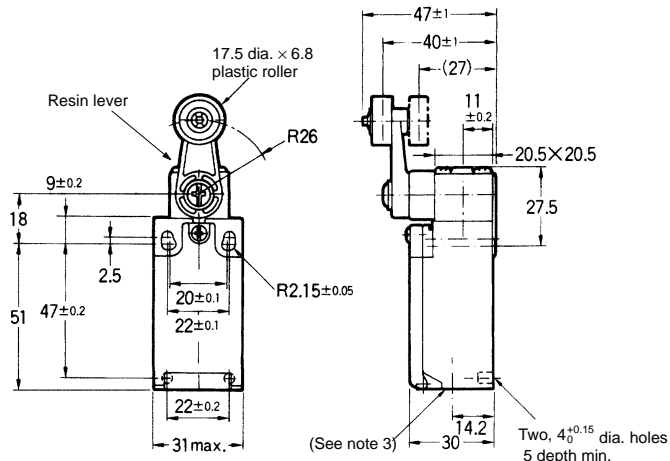

Roller Lever (Metal Lever)

D4D-□122N

D4D-□522N

D4D-□A22N

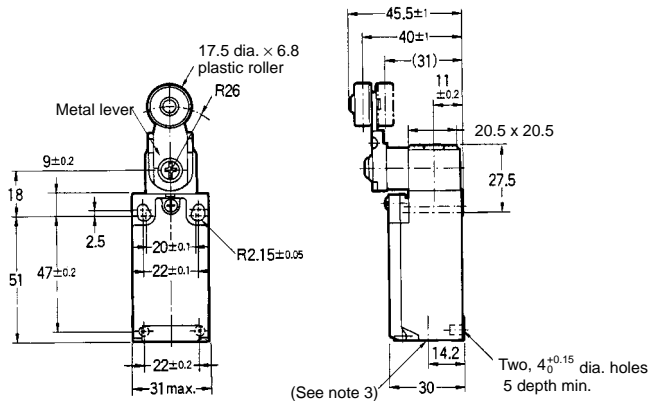

Adjustable Roller Lever

D4D-□121N

D4D-□521N

D4D-□A21N

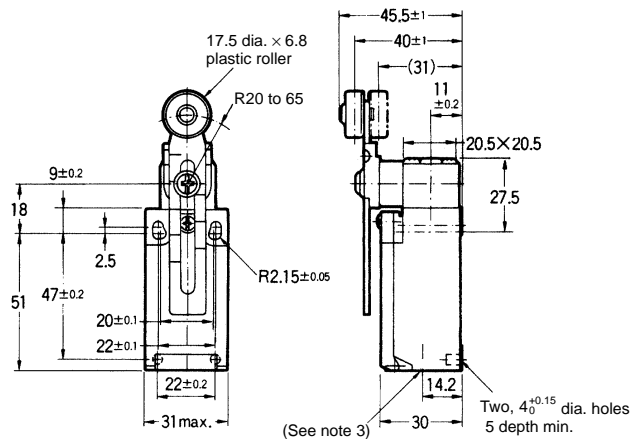
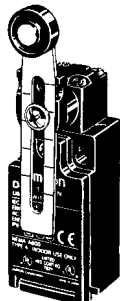

**Adjustable Roller Lever
(with Rubber Roller)**

D4D-□127N
D4D-□527N
D4D-□A27N

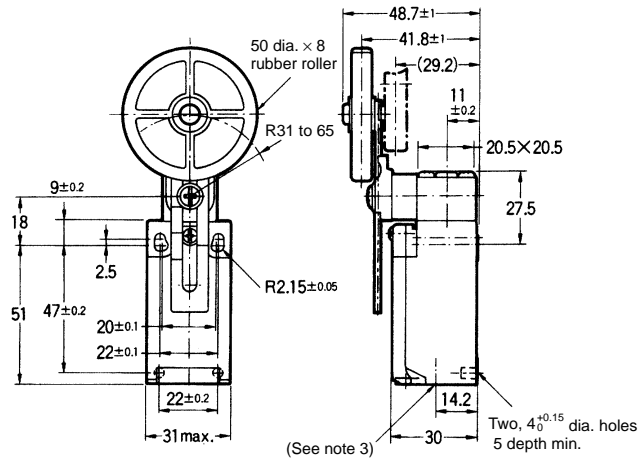
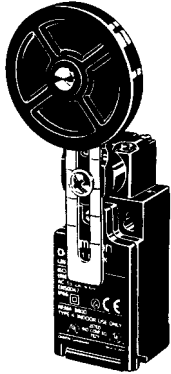

Plunger

D4D-□131N
D4D-□531N
D4D-□A31N

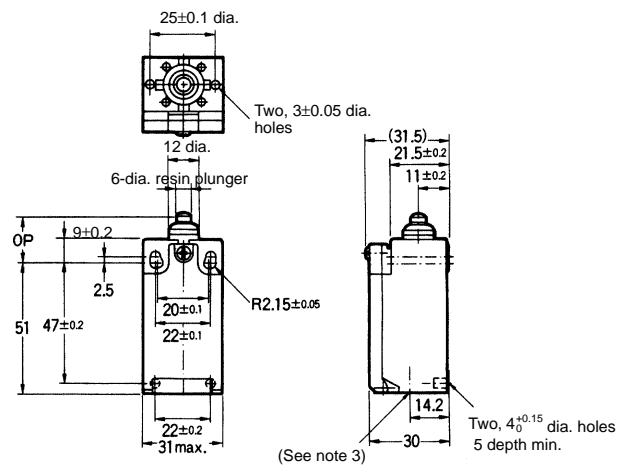

Roller Plunger

D4D-□132N
D4D-□532N
D4D-□A32N

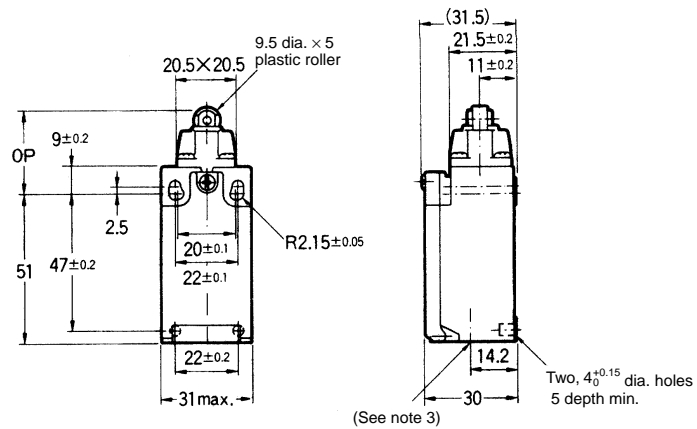

**One-way Roller Arm Lever
(Horizontal)**
D4D-□162N
D4D-□562N
D4D-□A62N

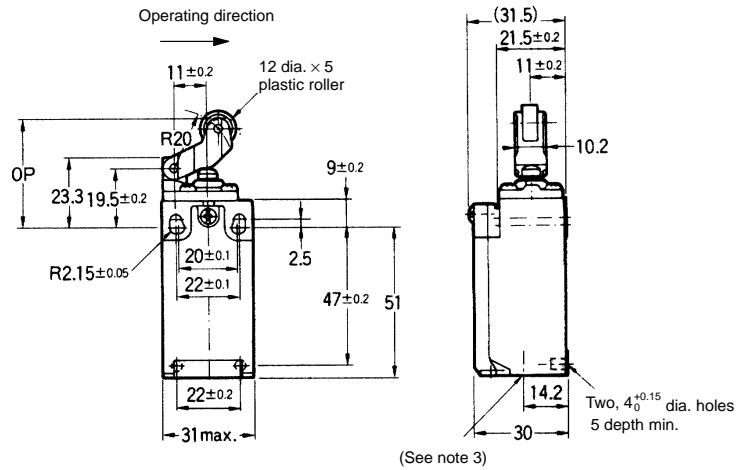

**One-way Roller Arm Lever
(Vertical)**
D4D-□172N
D4D-□572N
D4D-□A72N

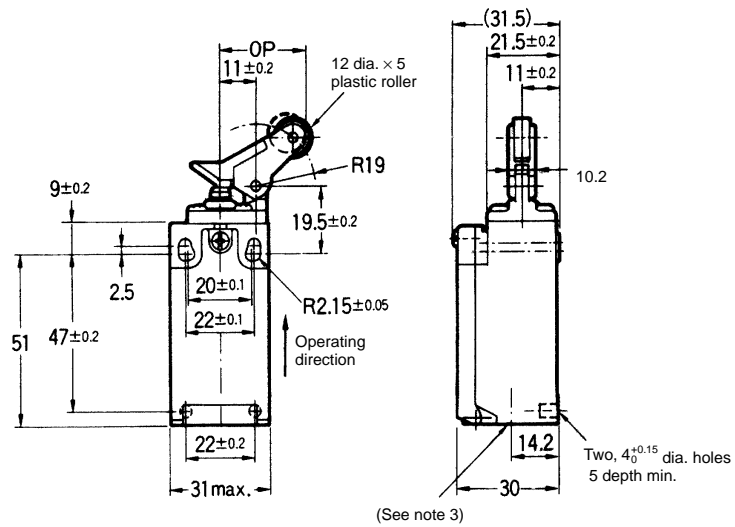

**Fork Lever Lock
(Right Operation)**
D4D-15REN

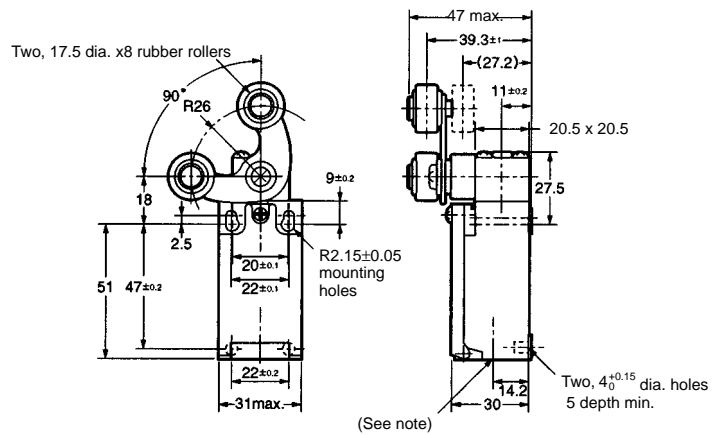
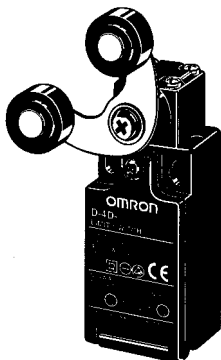

**Fork Lever Lock
(Left Operation)
D4D-15LEN**

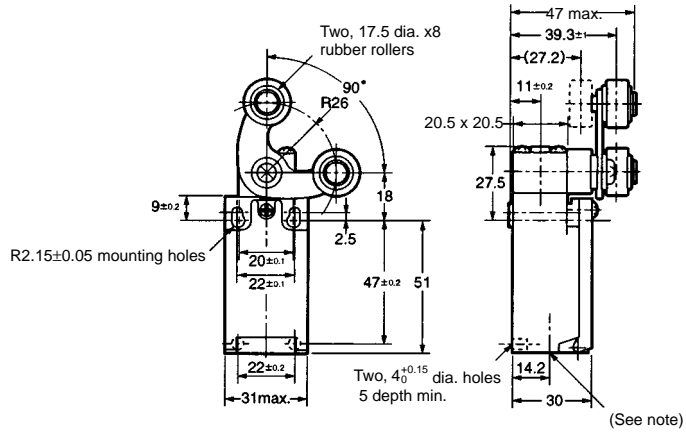

**Cat Whisker
D4D-□□80N**

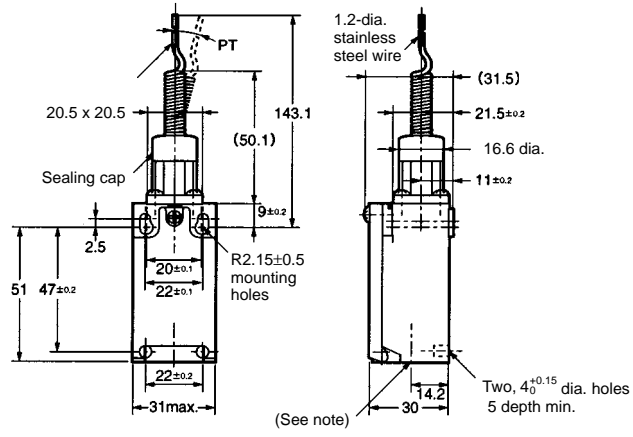

**Plastic Rod
D4D-□□87N**

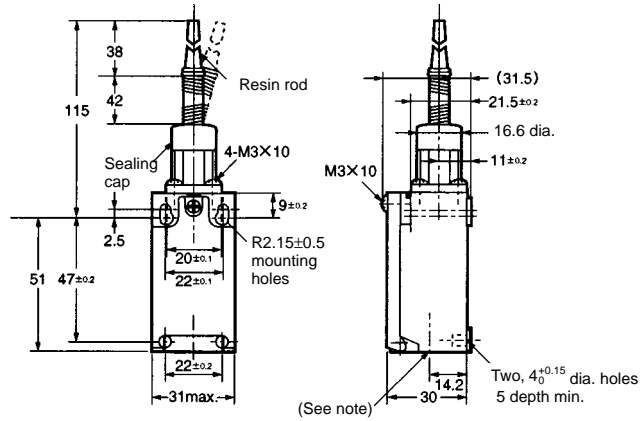

■ 2-conduit Models

- Note:**
1. All units are in millimeters unless otherwise indicated.
 2. Unless otherwise specified, a tolerance of ± 0.4 mm applies to all dimensions.
 3. When placing your order, specify the conduit type by adding a code from the list below to the blank box of the following model numbers as shown below.
5: PG 13.5
6: G 1/2
 4. The minimum number of screw threads is five when the Pg13.5 conduit is used and four when the G1/2 conduit is used.

Roller Lever (Resin Lever)

- D4D-□120N
- D4D-□520N
- D4D-□A20N

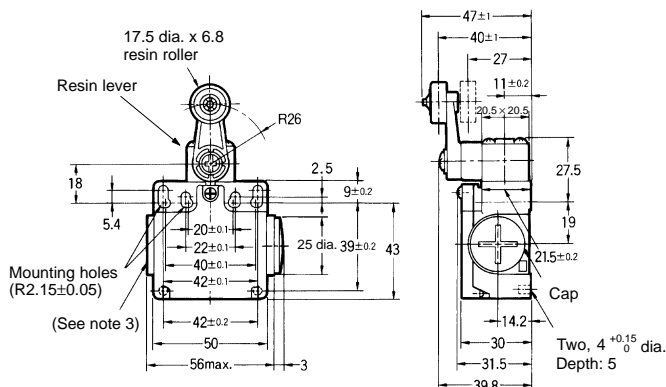
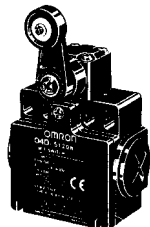

Roller Lever (Metal Lever)

- D4D-□122N
- D4D-□522N
- D4D-□A22N

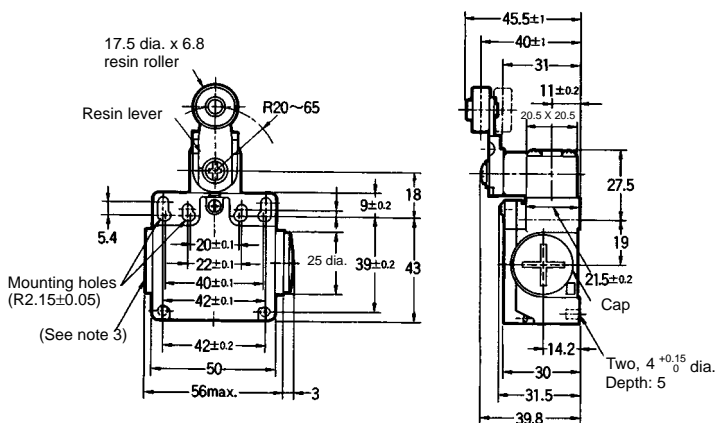
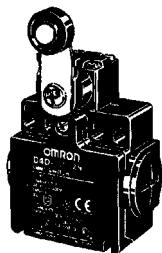

Adjustable Roller Lever

- D4D-□121N
- D4D-□521N
- D4D-□A21N

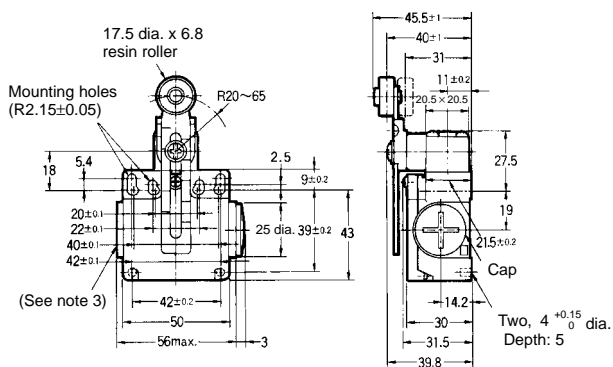
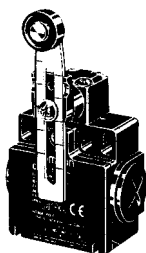

**Adjustable Roller Lever
(Rubber Roller Lever)**

D4D-□127N
D4D-□527N
D4D-□A27N

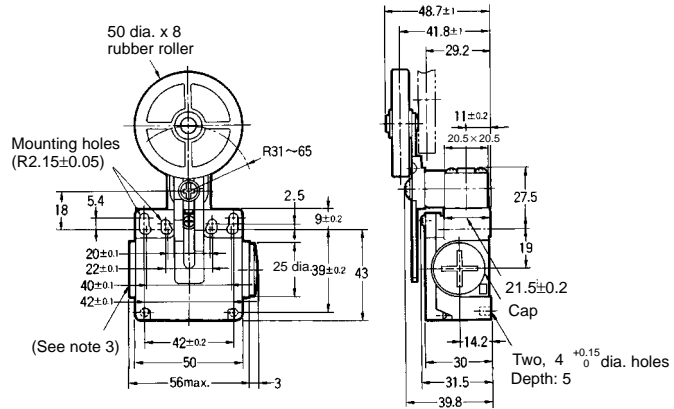
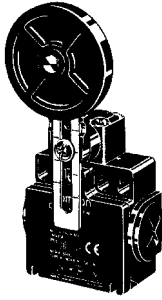

Plunger

D4D-□131N
D4D-□531N
D4D-□A31N

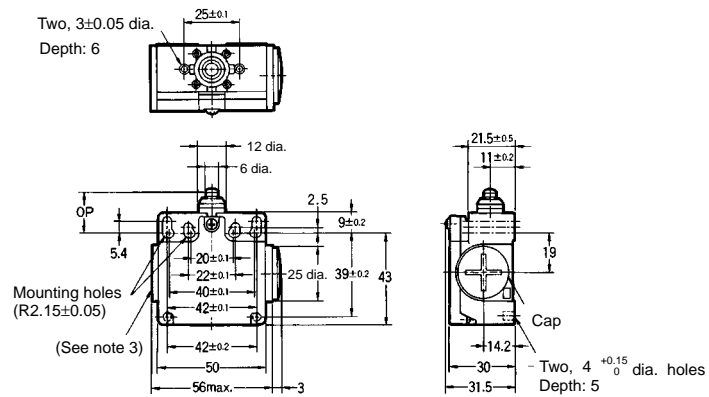

Roller Plunger

D4D-□132N
D4D-□532N
D4D-□A32N

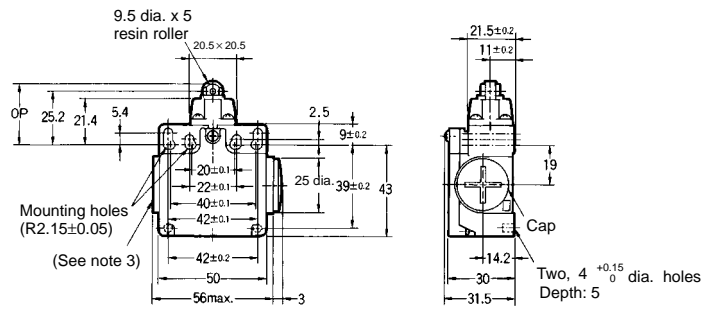
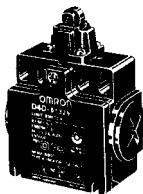

**One-way Roller Arm Lever
(Horizontal)**

D4D-□162N
D4D-□562N
D4D-□A62N

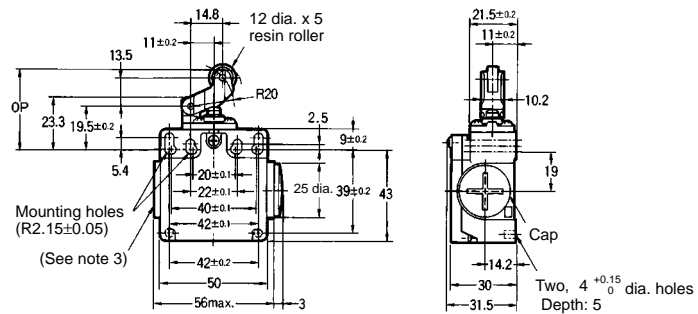
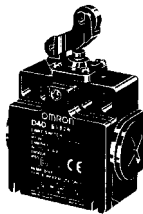

**One-way Roller Arm Lever
(Vertical)**

D4D-□172N
D4D-□572N
D4D-□A72N

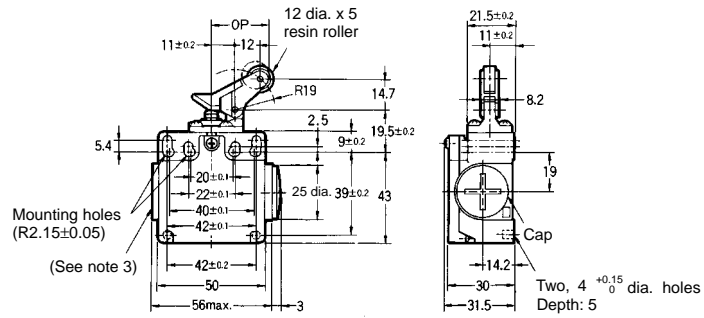

**Fork Lever Lock
(Right Operation)**

D4D-55REN

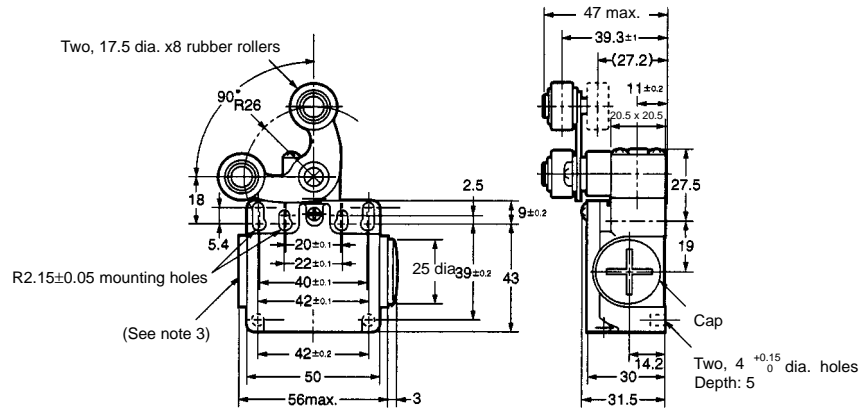
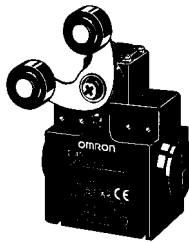

**Fork Lever Lock
(Left Operation)**

D4D-55LEN

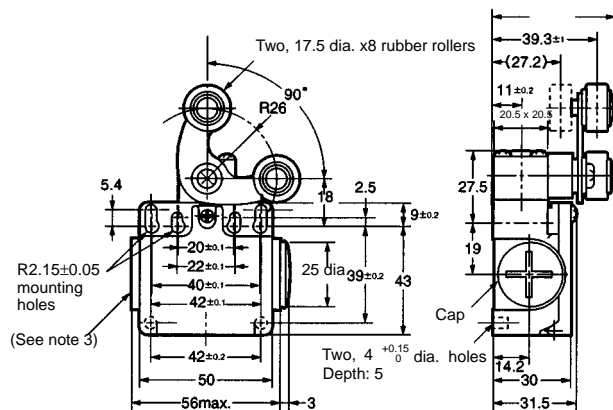

Cat Whisker

D4D-□180N
D4D-□A80N

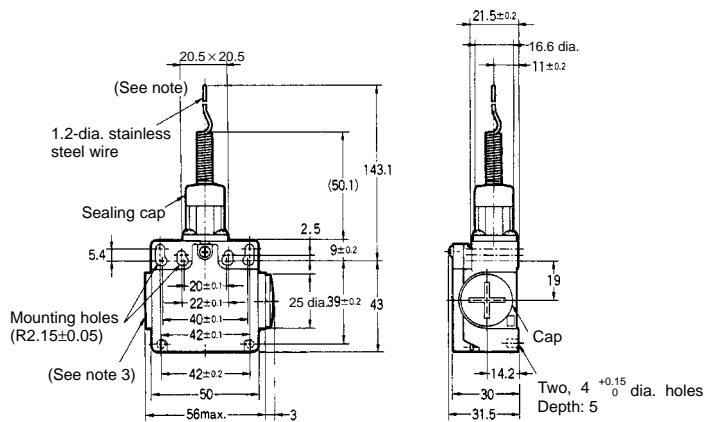
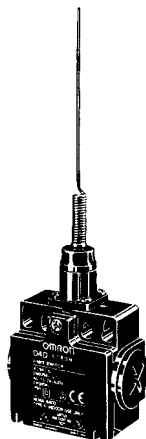

Plastic Rod
D4D-□187N
D4D-□A87N

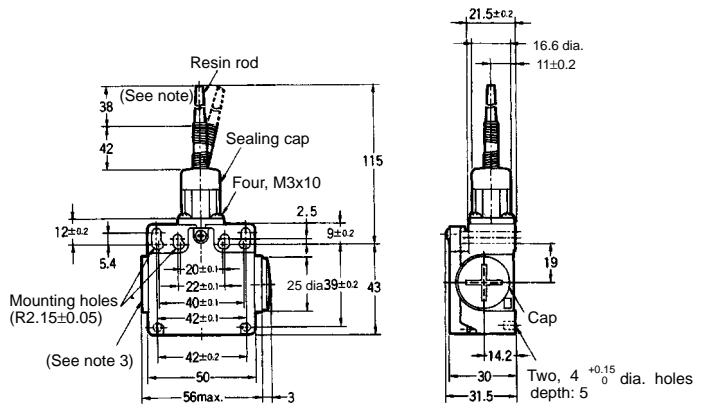
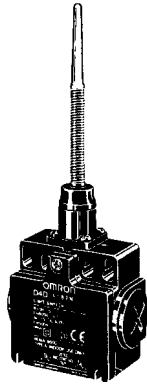

Levers

Refer to the following for the angles and positions of the watchdogs.

Roller Lever

(D4D-□□20N, D4D-□□22N)

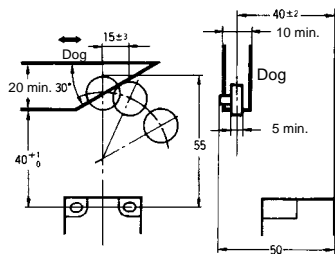

Adjustable Roller Lever

(D4D-□□21N) (Reference Value)

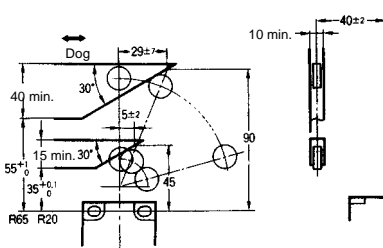

Adjustable Roller Lever (Rubber Roller Lever)

(D4D-□□27N) (Reference Value)

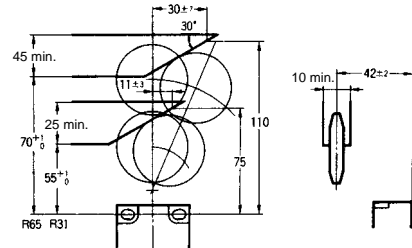

Sealed Plunger

(D4D-□□31N)

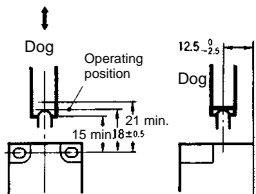

Roller Plunger

(D4D-□□32N)

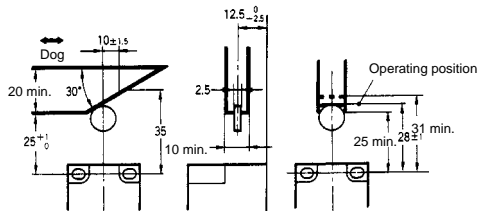

One-way Roller Arm Lever (Horizontal)

(D4D-□□62N)

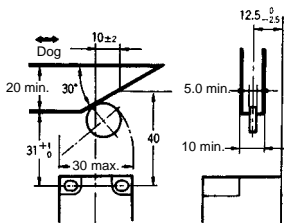

One-way Roller Arm Lever (Vertical)

(D4D-□□72N)

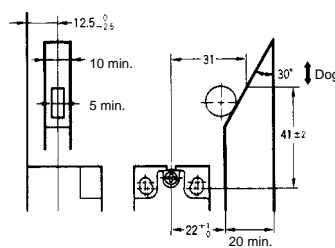

Precautions

▲ CAUTION

Do not use metal connectors or conduits to wire the Limit Switch, otherwise the conduit of the Limit Switch may break and an electric shock may be received.

- If the D4D-□N is applied to an emergency stop circuit or safety circuit for prevention of injury, use a D4D-□N model that has an NC contact equipped with a force-separation mechanism, and make sure that the D4D-□N operates in the positive mode. Furthermore, secure the D4D-□N with screws or equivalent parts that are tightened in a single direction so that the D4D-□N cannot be easily removed. Then provide a protection cover for the D4D-□N and post a warning label near the D4D-□N.
- Be sure to connect a fuse with a breaking current 1.5 to 2 times larger than the rated current to the Limit Switch in parallel in order to protect the Limit Switch from damage due to short-circuiting.
- When using the Limit Switch for the EN ratings, use the gI or gG 10-A fuse.

Operating Environment

The Limit Switch is intended for indoor use only. Using the Limit Switch outdoors may result in a malfunction.

Correct Tightening Torque

A loose screw may result in a malfunction. Be sure to tighten each screw to the proper tightening torque as shown below.

No.	Type	Torque
1	Terminal screw	0.59 to 0.78 N • m
2	Cover mounting screw	0.78 to 0.88 N • m
3	Head mounting screw	0.78 to 0.88 N • m
4	Lever mounting screw	1.57 to 1.77 N • m
5	Switch mounting screw (M4)	0.49 to 0.69 N • m
6	Connector	1.8 to 2.2 N • m 1.37 to 1.77 N • m (see note)
7	Cap screw	1.27 to 1.67 N • m

Note: This applies to the 1/2-14NPT connector.

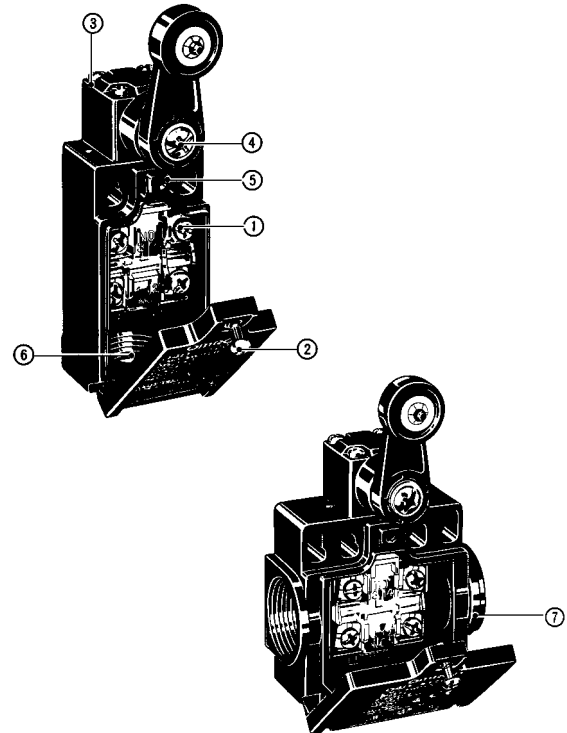

Operating Method

Use of the Limit Switch at an improper dog angle, operating speed, or operating direction will eventually cause a failure in Limit Switch. Make sure that the dog angle, operating speed, and operating direction are within the specified ranges. Do not set the dog angle to 90°.

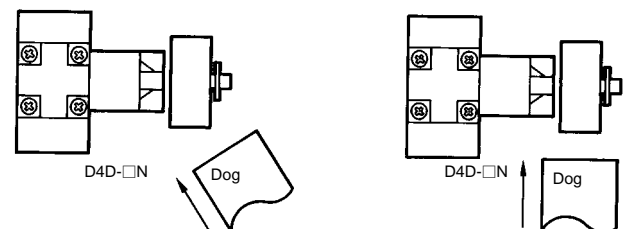

Mounting

Fasten the Switch with two M4 Allen-head bolts and washers. Provide a stud with a diameter of $4^{-0.05}/_{-0.15}$ and a height of 4.8 mm max. at two places as shown below so that the Switch is firmly fixed at four points.

Mounting Holes/Studs

1-conduit Models

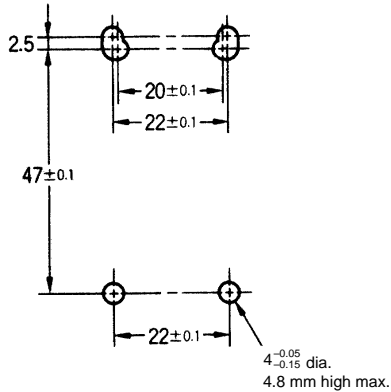

2-conduit Models

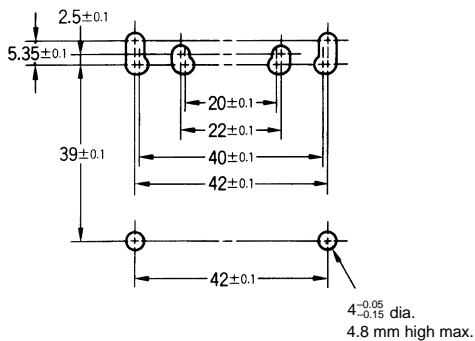

Changing the Lever Angle

- To change the angle of the lever, loosen the lever mounting screw. Then the lever can be set at any angle in 7.5° increments.
- The length of a variable roller lever can be changed by loosening the lever mounting screw.
- The lever mounting position may be inside out after removing the lever mounting screw. Make sure that the lever will not touch the Switch when the lever is mounted inside out.

Changing the Head Direction

If the head direction has been changed, check the torque of each screw and make sure that the screws are free of foreign substances, and that each screw is tightened to the proper torque.

Wiring

- Do not connect the bare lead wires directly to the terminals but be sure to connect each of them by using an insulation tube and M3.5 round solderless terminals and tighten each terminal screw within the specified torque range.
- The proper lead wire is 20 to 14 AWG (0.5 to 2.5 mm²) in size.

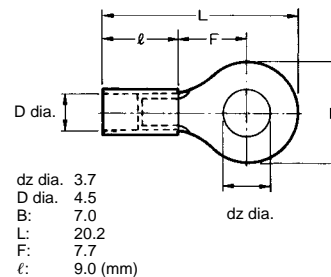

Perform wiring for the crimp terminals in the orientation shown below, so that they are not resting on the case or the cover.

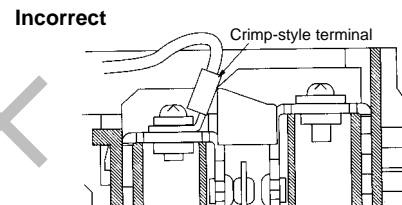
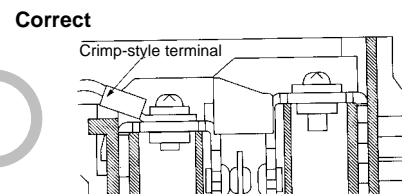
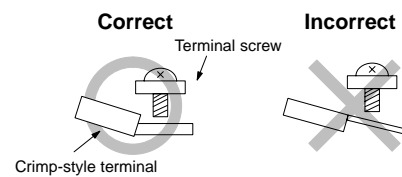

Processing the Conduit Opening

Tighten the connector to a torque of 1.8 to 2.2 N · m (1.37 to 1.77 N · m if it is a 1/2-14NPT). Excessive tightening torque may damage the casing. To satisfy IP65, apply sealing tape to the connector conduit.

The diameter of the cable must be suited to the corresponding connector.

When performing wiring, close conduit openings in any places that will not be used using the cap screws provided as accessories. Tighten the screws to the applicable torque.

Recommended Connector

Conduit size	Manufacturer	Model	Applicable cable diameter
G1/2	OMRON	SC-6	7.5 to 9.0 mm
	LAPP (see note 1)	ST-PF1/2 5380-1002	6.0 to 12.0 mm
	Ohm Denki (see note 2)	OA-W1609	7.0 to 9.0 mm
Pg13.5	LAPP (see note 1)	ST13.5 5301-5030	5.0 to 12.0 mm
1/2-14NPT	LAPP (see note 1)	ST-NPT1/2 5301-6030	6.0 to 12.0 mm

- Note:** 1. LAPP is a German manufacturer.
2. Ohm Denki is a Japanese manufacturer.

OMRON

OMRON Corporation

Industrial Automation Company

Industrial Devices and Components Division H.Q.
Industrial Control Components Division
28th Fl., Crystal Tower Bldg.,
1-2-27, Shiromi, Chuo-ku, Osaka 540-6028 Japan
Phone: (81)6-6949-6025 Fax: (81)6-6949-6029

Regional Headquarters

OMRON EUROPE B.V.

Wegalaan 67-69, NL-2132 JD Hoofddorp
The Netherlands
Tel: (31)2356-81-300/Fax: (31)2356-81-388

OMRON ELECTRONICS, INC.

1 East Commerce Drive, Schaumburg, IL 60173
U.S.A.
Tel: (1)847-843-7900/Fax: (1)847-843-8568

OMRON ASIA PACIFIC PTE. LTD.

83 Clemenceau Avenue,
#11-01, UE Square,
Singapore 239920
Tel: (65)835-3011/Fax: (65)835-2711

Authorized Distributor:

ALL DIMENSIONS SHOWN ARE IN MILLIMETERS.

To convert millimeters into inches, multiply by 0.03937. To convert grams into ounces, multiply by 0.03527.