

High-speed, Intelligent Interface Modules with Seven Operating Modes Convert Single or Dual Input Pulses to Display Values

- 50-kHz input range and 0.006% accuracy for sophisticated control.
- A wide selection of outputs: relay, transistor, BCD, linear, or communications.
- Maximum/Minimum value hold, set value write protection, and more.
- Banks with four comparative output values and four prescale values.
- Prescale function available, which displays in units of actual physical parameters (length, volume, etc.).
- Set value teaching, linear output range teaching, and prescale teaching are available using actual measured values.
- Displays values in hours, minutes, and seconds in operating mode 6.
- A startup compensation time parameter keeps the measurement operation from sending an unnecessary output for a preset period up to 99.9 s.
- Built-in sensor power supply (12 VDC, 80 mA).
- Compact 1/8 DIN size.
- Conforms to EMC standards, EN61010-1 (IEC61010-1).
- UL/CSA approved.



Ordering Information

■ Base Unit

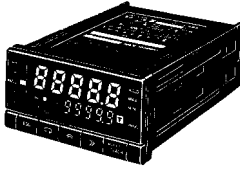
Input type	NPN/Voltage pulse		PNP	
	100 to 240 VAC	12 to 24 VDC	100 to 240 VAC	12 to 24 VDC
Basic Models These models provide a present value LED and front-panel control keys. Can be connected to any Output Board, or can be used for display only without an Output Board. 	K3NR-NB1A	K3NR-NB2A	K3NR-PB1A	K3NR-PB2A
Set Value LED Models These models provide a present value LED, set value LED, and front-panel control keys. Can be connected to Relay, Transistor, or Combination Output Boards. 	K3NR-NB1C	K3NR-NB2C	K3NR-PB1C	K3NR-PB2C

■ Available Output Board Combinations

Output type	Output configuration	Output boards	Base units	
			Basic	Set Value LED Display
Relay contact	3 outputs: H, PASS, L (SPDT)	K31-C1	Yes	Yes
	5 outputs: HH, H, L, LL (SPST-NO), and PASS (SPDT)	K31-C2	Yes	Yes
	5 outputs: HH, H, L, LL (SPST-NC), and PASS (SPDT)	K31-C5	Yes	Yes
Transistor	5 outputs (NPN open collector)	K31-T1	Yes	Yes
	5 outputs (PNP open collector)	K31-T2	Yes	Yes
BCD (see note)	5-digit output (NPN open collector)	K31-B2	Yes	---
Linear	4 to 20 mA DC	K31-L1	Yes	---
	1 to 5 VDC	K31-L2	Yes	---
	1 mV/10 digits	K31-L3	Yes	---
	0 to 5 VDC	K31-L7	Yes	---
	0 to 10 VDC	K31-L8	Yes	---
Communication boards (see note)	RS-232C	K31-FLK1	Yes	---
	RS-485	K31-FLK2	Yes	---
	RS-422	K31-FLK3	Yes	---
Combination output and communication boards	BCD output + 5 transistor outputs (NPN open collector)	K31-B4	Yes	Yes
	4 to 20 mA + 5 transistor outputs (NPN open collector)	K31-L4	Yes	Yes
	1 to 5 V + 5 transistor outputs (NPN open collector)	K31-L5	Yes	Yes
	1 mV/10 digits + 5 transistor outputs (NPN open collector)	K31-L6	Yes	Yes
	0 to 5 VDC + 5 transistor outputs (NPN open collector)	K31-L9	Yes	Yes
	0 to 10 VDC + 5 transistor outputs (NPN open collector)	K31-L10	Yes	Yes
	RS-232C + 5 transistor outputs (NPN open collector)	K31-FLK4	Yes	Yes
	RS-485 + 5 transistor outputs (NPN open collector)	K31-FLK5	Yes	Yes
RS-422 + 5 transistor outputs (NPN open collector)	K31-FLK6	Yes	Yes	

Note: For details, refer to the *Communication Operation Manual*.

Model Number Legend:

Base Units and Output Boards can be ordered individually or as sets. Refer to the *Output Board Combinations* table on page 2.

Base Units

K3NR -
 1 2 3 4

Output Boards

K31 -
 5 6 7 8

Base Units with Output Boards

K3NR - -
 1 2 3 4 5 6 7 8

1, 2. Input Sensors Codes

NB: NPN inputs

PB: PNP inputs

3. Supply Voltage

1: 100 to 240 VAC

2: 12 to 24 VDC

4. Display

A: Basic

C: Set Value LED Display

5, 6, 7, 8. Output Type Codes

C1: 3 comparative relay contact outputs (H, PASS, L: SPDT)

C2: 5 comparative relay contact outputs (HH, H, L, LL: SPST-NO; PASS: SPDT)

C5: 5 comparative relay contact outputs (HH, H, L, LL: SPST-NC; PASS: SPDT)

T1: 5 comparative transistor outputs (NPN open collector)

T2: 5 comparative transistor outputs (PNP open collector)

B2: BCD output (NPN open collector) (see note)

B4: BCD output + 5 transistor outputs (NPN open collector)

L1: Linear output (4 to 20 mA) (see note)

L2: Linear output (1 to 5 VDC) (see note)

L3: Linear output (1 mV/10 digits) (see note)

L4: Linear output, 4 to 20 mA + 5 transistor outputs (NPN open collector)

L5: Linear output, 1 to 5 V + 5 transistor outputs (NPN open collector)

L6: Linear output, 1 mV/10 digits+ 5 transistor outputs (NPN open collector)

L7: Linear output, 0 to 5 VDC (see note)

L8: Linear output, 0 to 10 VDC (see note)

L9: Linear output, 0 to 5 VDC + 5 transistor outputs (NPN open collector)

L10: Linear output, 0 to 10 VDC + 5 transistor outputs (NPN open collector)

FLK1: Communication RS-232C (see note)

FLK2: Communication RS-485 (see note)

FLK3: Communication RS-422 (see note)

FLK4: RS-232C + 5 transistor outputs (NPN open collector)

FLK5: RS-485 + 5 transistor outputs (NPN open collector)

FLK6: RS-422 + 5 transistor outputs (NPN open collector)

Note: These output types are available on Basic Models only.

Specifications

■ Ratings

Supply voltage	100 to 240 VAC (50/60 Hz); 12 to 24 VDC
Operating voltage range	85% to 110% of supply voltage
Power consumption (see note)	15 VA max. (max. AC load with all indicators lit) 10 W max. (max. DC load with all indicators lit)
Sensor power supply	80 mA at 12 VDC±10%
Insulation resistance	20 MΩ min. (at 500 VDC) between external terminal and case. Insulation provided between inputs, outputs, and power supply.
Dielectric withstand voltage	2,000 VAC for 1 min between external terminal and case. Insulation provided between inputs, outputs, and power supply.
Noise immunity	±1,500 V on power supply terminals in normal or common mode ±1 μs, 100 ns for square-wave noise with 1 ns
Vibration resistance	Malfunction: 10 to 55 Hz, 0.5-mm for 10 min each in X, Y, and Z directions Destruction: 10 to 55 Hz, 0.75-mm for 2 hrs each in X, Y, and Z directions
Shock resistance	Malfunction: 98 m/s ² (10G) for 3 times each in X, Y, and Z directions Destruction: 294 m/s ² (30G) for 3 times each in X, Y, and Z directions
Ambient temperature	Operating: -10°C to 55°C (with no icing) Storage: -20°C to 65°C (with no icing)
Ambient humidity	Operating: 25% to 85% (with no condensation)
Ambient atmosphere	Must be free of corrosive gas
EMC	Emission Enclosure: EN55011 Group 1 class A Emission AC Mains: EN55011 Group 1 class A Immunity ESD: EN61000-4-2:4-kV contact discharge (level 2) 8-kV air discharge (level 3) Immunity-RF-interference: ENV50140: 10 V/m (amplitude modulated, 80 MHz to 1 GHz) (level 3) 10 V/m (pulse modulated, 900 MHz) Immunity Conducted Disturbance: ENV50141: 10 V (0.15 to 80 MHz) (level 3) Immunity Burst: EN61000-4-4:2-kV power-line (level 3) 2-kV I/O signal-line (level 4)
Approved standards	UL508, CSA22.2; conforms to EN50081-2, EN50082-2, EN61010-1 (IEC61010-1); conforms to VDE106/part 100 (Finger Protection) when the terminal cover is mounted.
Weight	Approx. 400 g

Note: An Intelligent Signal Processor with DC supply voltage requires approximately 1 A DC as control power supply current the moment the Intelligent Signal Processor is turned on. Do not forget to take this into consideration when using several Intelligent Signal Processors. When the Intelligent Signal Processor is not in measuring operation (e.g., the Intelligent Signal Processor has been just turned on or is operating for startup compensation time), the display will read "00000" and all outputs will be OFF.

Input/Output Ratings

Relay Contact Output

(Incorporating a G6B Relay)

Item	Resistive load ($\cos\phi = 1$)	Inductive load ($\cos\phi = 0.4$, L/R = 7 ms)
Rated load	5 A at 250 VAC; 5 A at 30 VDC	1.5 A at 250 VAC, 1.5 A at 30 VDC
Rated carry current	5 A max. (at COM terminal)	
Max. contact voltage	380 VAC, 125 VDC	
Max. contact current	5 A max. (at COM terminal)	
Max. switching capacity	1,250 VA, 150 W	375 VA, 80 W
Min. permissible load (P level, reference value)	10 mA at 5 VDC	
Mechanical life	50,000,000 times min. (at a switching frequency of 18,000 times/hr)	
Electrical life (at an ambient temperature of 23°C)	100,000 times min. (at a rated load switching frequency of 1,800 times/hr)	

Transistor Output

Rated load voltage	24 VDC max.
Max. load current	50 mA
Leakage current	100 μA max.

BCD Output

I/O signal name		Item	Rating
Inputs	REQUEST, HOLD, MAX, MIN, RESET	Input signal	No-voltage contact input
		Input current with no-voltage input	10 mA
		Signal level	ON voltage: 1.5 V max. OFF voltage: 3 V min.
Outputs	DATA, POLARITY, OVERFLOW, DATA VALID, RUN	Rated load voltage	24 VDC max.
		Max. load current	10 mA
		Leakage current	100 μ A max.

Note: Logic method: negative logic

Linear Output

Item	4 to 20 mA	1 to 5 V	1 mV/10 digits (see note)
Resolution	4,096		
Output error	$\pm 0.5\%$ FS		$\pm 1.5\%$ FS
Permissible load resistance	600 Ω max.	500 Ω min.	1 K Ω min.

Note: For the 1 mV/10-digit output, the output voltage changes for every 40 to 50 increment in the display value.

■ Communications

Item		RS-232C, RS-422	RS-485
Transmission method		4-wire, half-duplex	2-wire, half-duplex
Synchronization method		Start-stop synchronization	
Baud rate		1,200/2,400/4,800/9,600/19,200/38,400 bps	
Transmission code		ASCII (7-bit)	
Communications	Write to K3NR	Comparative set value, prescaling value, remote/local programming, reset control of maximum/minimum values, and other setting mode items excluding communications conditions.	
	Read from K3NR	Process value, comparative set value, maximum value, minimum value, model data, error code, and others	

For details, refer to *Communication Operation Manual*.

■ Characteristics

Input signal	No-voltage contact (30 Hz max., ON/OFF pulse width: 15 ms min.) Voltage pulse (50 kHz max., ON/OFF pulse width: 9 μs min., ON voltage: 4.5 to 30 V/OFF voltage: -30 to 2 V) Open collector (50 kHz max., ON/OFF pulse width: 9 μs min.) Connectable Sensors ON residual voltage: 3 V max. OFF leakage current: 1.5 mA max. Load current: Must have switching capacity of 20 mA min. Must be able to dependably switch a load current of 5 mA max.
Measuring accuracy (at 23±5°C)	Operating modes 1 and 6: ±0.006%rdg±1 digit Operating modes 2 to 5: ±0.02%rdg±1 digit
Measuring modes and ranges (Operating modes 1 to 6 are for no-contact sensor models)	Operating mode 1: Rotational/circumferential speed 0.0005 to 50,000 Hz Operating mode 2: Absolute ratio 0.0005 to 50,000 Hz Operating mode 3: Error ratio 0.0005 to 50,000 Hz Operating mode 4: Rotational difference 0.0005 to 50,000 Hz Operating mode 5: Flow rate ratio 0.0005 to 50,000 Hz Operating mode 6: Passing time 0.0005 to 50,000 Hz Operating mode 7: Pulse counting 0 to 4G count (32-bit counter)
Max. displayed digits	5 digits (-19999 to 99999)
Display	7-segment LED
Polarity display	"-" is displayed automatically with a negative input signal.
Zero display	Leading zeros are not displayed.
Prescale function	Programming via front-panel key inputs. (0.0001 x 10 ⁻⁹ to 9.9999 x 10 ⁹ , decimal point can be set freely) Can be set using prescale value teaching.
HOLD functions (see note 2)	Max. value (peak) hold, Min. value (bottom) hold
External control	HOLD (Process value held) RESET (Maximum/minimum data reset, counting value reset) BANK (Selection of one bank out of 4 banks of set values) (Selection of one bank out of 4 banks of prescale values)
Comparative output hysteresis setting	Programmable with front-panel key inputs (1 to 9999).
Other functions	Variable linear output range (for models with linear outputs only) (note 1) Remote/Local processing (available for communications output models only) Maximum/Minimum value data reset with front panel keys Comparative output pattern selection Process time for averaging measured values Startup compensation time (0.0 to 99.9 s) Time unit display Security Memory power failure
Output configuration	Relay contact output (3 or 5 outputs) Transistor output (NPN and PNP open collector), BCD (NPN open collector) Parallel BCD (NPN open collector) + transistor output (NPN open collector) Linear output (4 to 20 mA, 1 to 5 V) + transistor output (NPN open collector) Communication functions (RS-232C, RS-485, RS-422) Communication functions (RS-232C, RS-485, RS-422) + transistor output (NPN open collector)
Delay in comparative outputs (at transistor output)	Operating modes 1 to 6: 200 ms max. Operating mode 7: 1 ms max.
Enclosure rating	Front panel: NEMA4X for indoor use (equivalent to IP66) Rear case: IEC standard IP20 Terminals: IEC standard IP00
Memory protection	Non-volatile memory (EEPROM) (possible to rewrite 100,000 times)

- Note:** 1. The linear output range cannot be set when connected to a 1 mV/10-digit Linear Output Board.
2. Not effective for operating mode 7.

Engineering Data

Derating Curve for Sensor Power Supply

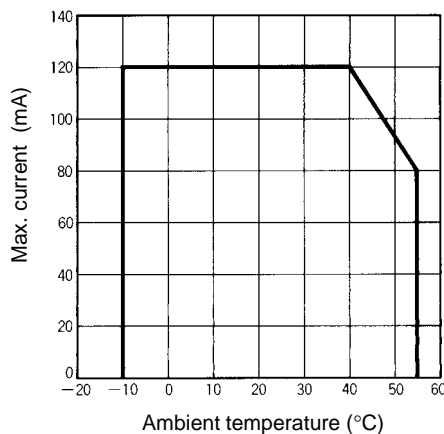

Note: The derating curve shown is for standard installation. The derating curve depends on the mounting direction.

Nomenclature

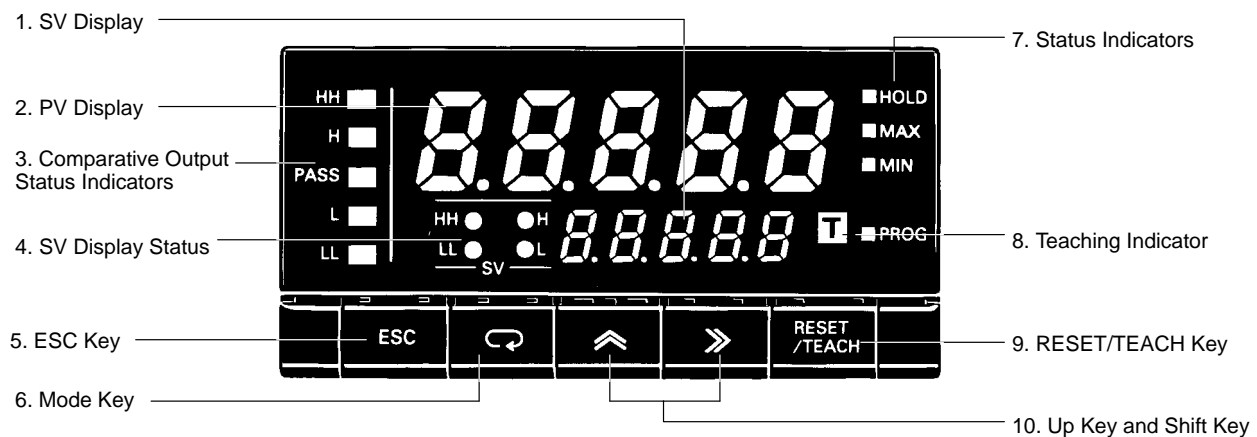

Name	Functions
1. SV display	Displays the set value or parameter. Available for Set Value LED Models only.
2. PV display	Displays the process value in addition to the max./min. value or parameter.
3. Comparative output status indicators	Displays the status of comparative output.
4. SV display status	Indicates which comparative set value is currently on the SV display.
5. ESC Key	Used to return to the RUN mode from the Setting, Protect, or Maintenance mode. The process value, maximum value, or minimum value to be displayed can be selected.
6. Mode Key	Used to enter the Setting mode. Used to allow the PV display to indicate set values sequentially. Available for Basic Models only. Used to indicate set values sequentially on the SV display. Available for Set Value LED Models only.
7. Status indicators	HOLD: Lit when HOLD input is ON. MAX: Lit when the maximum value is indicated on the PV display. MIN: Lit when the minimum value is indicated on the PV display. PROG: Lit or flashes while parameters are being set.
8. Teaching indicator	Lit when the teaching function is enabled and flashes when the Intelligent Signal Processor is in teaching operation.
9. RESET/TEACH Key	The maximum value, minimum value, and counting values are reset by pressing this key. Teaching is available when the teaching function is enabled.
10. Up Key and Shift Key	The digit being set is scrolled by pressing the Shift Key. The set value increases by one whenever the Up Key is pressed.

Operation

■ Setting Procedures

The K3NR has four modes: RUN mode for normal operations, Setting mode for initial parameter input, Protect mode for lock-out configuration, and Maintenance mode for initializing set values. The parameters that are accessible on any individual K3NR will vary depending on the Output Board installed. Refer to the *K3NR Operation Manual* for details.

- RUN Mode:** Remains in this mode under normal operation.
The process value or the max./min. value can be monitored.
Using the front panel keys, the comparative set value can be changed and max./min. value and counting value reset can be performed.
- Setting Mode:** Used for making initial settings.
Includes settings for four menus (Set value (*SuSEt*), prescaling (*PSECL*), setup (*SEtUP*), option (*oPt*)) and the output test.
- Protect Mode:** Used for locking the front key operation or parameter changes.
- Maintenance Mode:** Used for initializing set values.

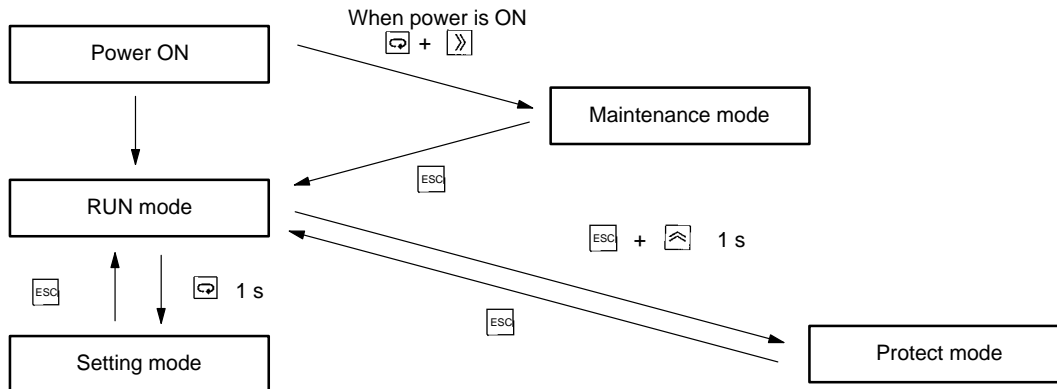

SuSEt - Program set values

- S.bRnH* Select bank no. of set values
- Su I.HH* Enter set value HH of bank 1
- Su I. H* Enter set value H of bank 1
- Su I. L* Enter set value L of bank 1
- Su I. LL* Enter set value LL of bank 1

Note: The above is an example when the bank number is set to 1.

PSECL - Display prescaling

- P.bRnH* Select bank no. of prescale values
- P5 I.Rx* Set the mantissa (X) of the prescale value of input A
- P5 I.Ry* Set the exponent (Y) of the prescale value of input A
- P5 I.bx* Set the mantissa (X) of the prescale value of input B
- P5 I.by* Set the exponent (Y) of the prescale value of input B
- dECP. I* Select decimal point

Note: The above is an example when the bank number is set to 1.

SEtUP - Program operating mode/input sensor/serial communications

- FUnC* Specify operating mode
- cnA* Select a sensor type of input A
- cnB* Select a sensor type of input B
- Erā.Rx* Set the mantissa (X) of the auto zero time of input A
- Erā.Ry* Set the exponent (Y) of the auto zero time of input A
- Erā.bx* Set the mantissa (X) of the auto zero time of input B
- Erā.by* Set the exponent (Y) of the auto zero time of input B

oPt - Supplementary settings related to display or control

- AVG* Set the process time for averaging measured value
- StcNE* Set startup compensation time
- nEno* Select power failure memory function
- HYS* Enter hysteresis value
- COULt* Select the output pattern
- LSEt.H* Enter the upper limit (H) of linear output range
- LSEt.L* Enter the lower limit (L) of linear output range
- rOL* Select the remote/local programming

tESL - Generating simulated input for testing the output function

Prōt - Program lock-out configuration

- ALL* Enable all key protection
- SuSEt* Enable set value change prohibition
- rESEt* Enable prohibition of counting value reset using the front panel keys
- nā.rSt* Enable prohibition of max./min. value reset using the front panel keys
- SECr* Specify the menus to be protected against setting in the setting mode

■ Parameters

Output Pattern Selection $\overline{O\overline{U\overline{T}}}$

The patterns of comparative output are selectable according to the level change. Select the pattern according to the application.

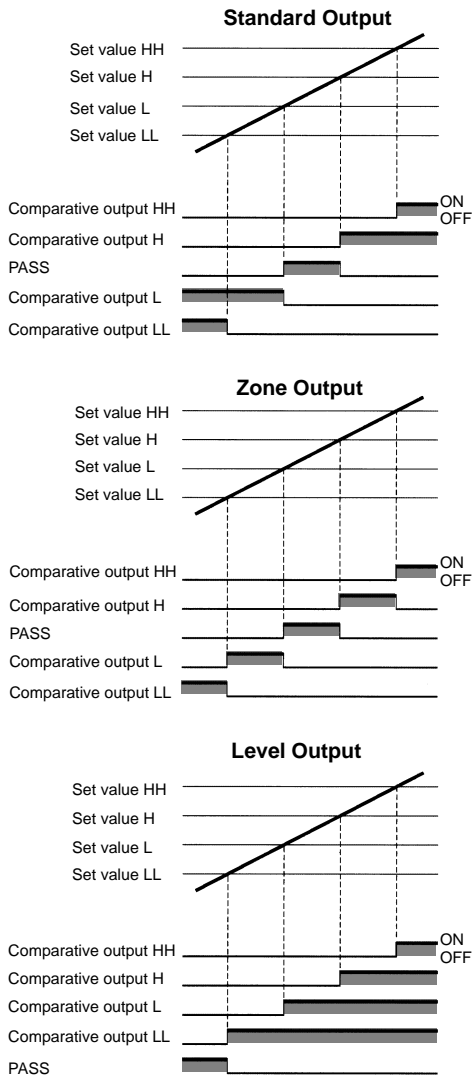

Note: The following setting conditions must be satisfied, otherwise no zone output will turn ON correctly.
 $LL < L < H < HH$

Startup Compensation Time $\overline{S\overline{T\overline{C\overline{O\overline{M}}}}}$

The startup compensation time parameter keeps the measurement operation from sending an unnecessary output corresponding to instantaneous, fluctuating input from the moment the K3NR is turned ON until the end of the preset period.

The compensation time can be set in a range from 0.0 to 99.9 seconds as the waiting time until the devices subject to measurement become stable after the startup of the power supply.

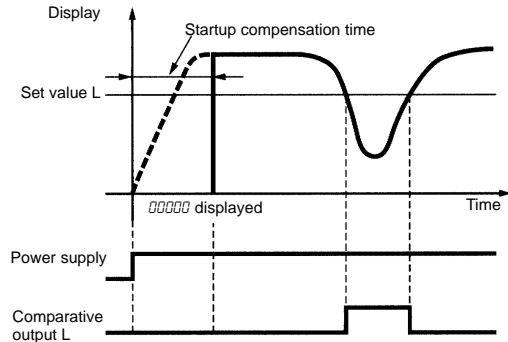

Hysteresis $\overline{H\overline{Y\overline{S}}}$

The hysteresis of comparative outputs can be set to prevent the chattering of comparative outputs. Refer to page 14 for more details.

Linear Output Range $\overline{L\overline{S\overline{E\overline{T}}}}$

A linear output range can be set as required. A value corresponding to the maximum output value and that corresponding to the minimum output value can be set.

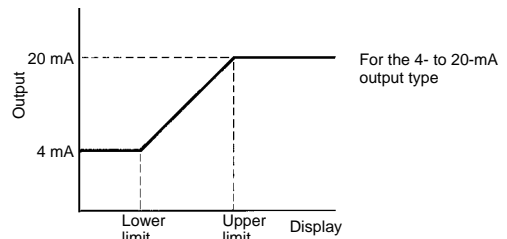

Remote/Local Selection $\overline{r\overline{L}}$

Select remote programming when performing all settings through the host devices and select local programming when performing settings through key operation.

Prescaling

To display rotational speeds, circumferential speeds, or other values based on input pulse calculations, the rotational speed must be multiplied by a factor input before the input pulses are measured. This factor is called a prescale value.

Prescale Value Example

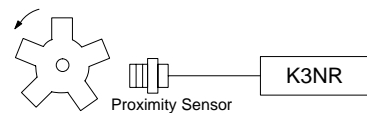

$rpm = f \times 60 \times \alpha$
Where,

f: Input pulse frequency (p/s)
 α : Prescale value

If there are 5 pulses per rotation, then an accurate rotations speed can be calculated if $\alpha = 1/5 (= 0.2 = 2 \times 10^{-1})$.

In actual application, input as follows;
 Mantissa X = $\times 2.0000$
 Exponent Y = $\times 10^{-1}$

Auto-zero Time

The time to force-zero the frequency if no pulse is received for a specified period can be set. This time is called the auto-zero time. Set the auto-zero time to a value that is somewhat longer than the longest input pulse interval. (If the time setting is too long or if the factory-set value is used, the display may not return to zero even if no input pulse is received.)

Terminal Arrangement

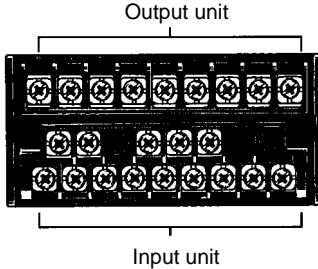

Process Time for Averaging Measured Value

Process time for averaging measured value is the time over which the measured values will be averaged. If this time is shorter than the input pulse interval, processing will be based on the input pulse interval.

Terminal Numbers

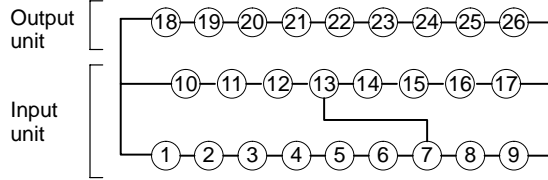

Note: Terminals 7 to 13 are connected internally.

Input Unit

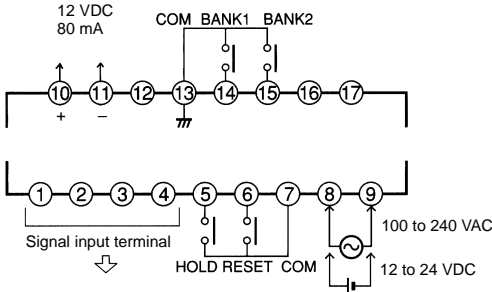

Note: Terminals 7 and 13 are insulated from each other.

When inputting the external control signals and input signals through the open collector:

- Transistor Inputs:
- ON: Residual voltage must be 3 V max.
- OFF: Leakage current must be 1.5 mA max.
- The switching capacity must be 20 mA or greater.

When the external signal input is short-circuited, a voltage of approximately 5 V will be applied to between the terminals 5 to 7 and the COM terminal, and a current of approximately 18 mA (nominal value) will flow.

K3NR-NB

(NPN Input/Voltage Pulse Input)

NPN Open Collector Output (NPN Linear 2-wire Output)

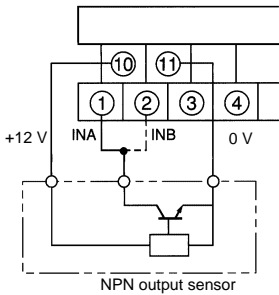

Note: Connect the + side of the NPN linear 2-wire input to terminal 1 and the - side to terminal 11.

Contact Output

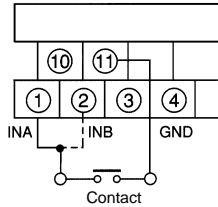

Voltage Output

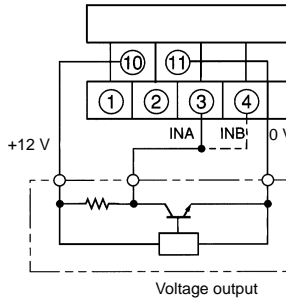

Note: With voltage pulse input not from a 3-wire sensor, connect the + side to terminal 3 and the - side to terminal 11.

K3NR-PB (PNP input)

PNP Open Collector Output

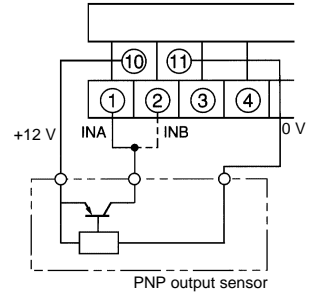

■ Output Boards

K31-C1: Relay (3 Outputs)

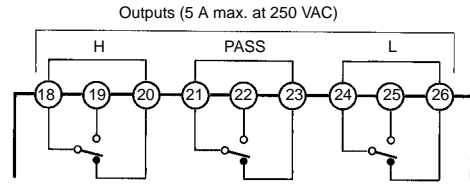

K31-C2: Relay (5 Outputs)

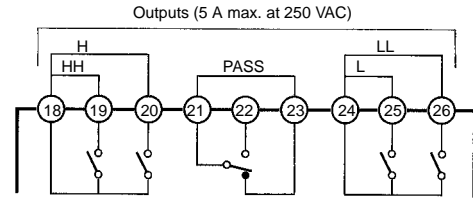

K31-C5: Relay (5 Outputs)

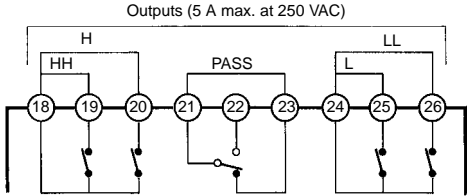

K31-T1: Transistor (NPN Open Collector)

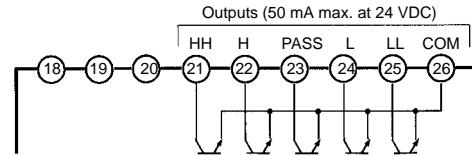

K31-T2: Transistor (PNP Open Collector)

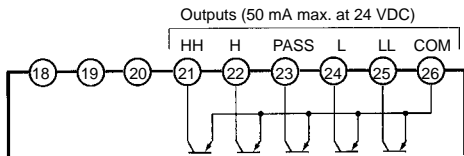

K31-B2, -B4: BCD (NPN Open Collector)
(Terminals 32 to 36 are provided only on K31-B4.)

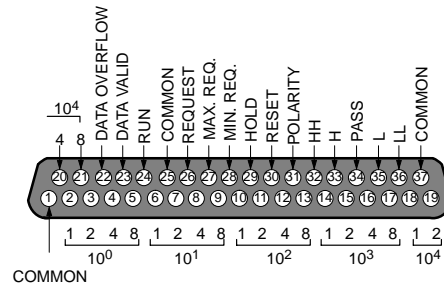

K31-L1, L2, L3, -L4, -L5, -L6, -L7, -L8, -L9, -L10: Linear
(Terminals 21 to 26 are provided only on K31-L4, -L5, -L6, -L9, -L10.)

- L1, L4: 4 to 20 mA
- L2, L5: 1 to 5 V
- L3, L6: 1 mV/10 digit
- L7, L9: 0 to 5 VDC
- L8, L10: 0 to 10 VDC

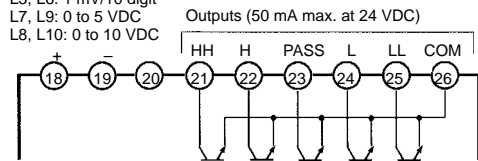

K31-FLK1: RS-232C

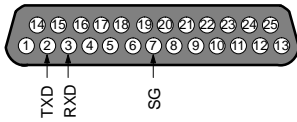

K31-FLK2, -FLK5: RS-485

(Terminals 21 to 26 are provided only on K31-FLK5.)

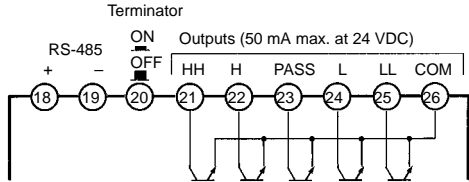

- D-sub 37P Connectors for BCD output (attachment)
Plug: XM2A-3701
Hood: XM2S-3711
- D-sub 25P connectors for RS-232C output (K31-FLK1) (order separately)
Plug: XM2A-2501
Hood: XM2S-2511
- D-sub 9P connectors for RS-422 output (K31-FLK3 and K31-FLK6) (order separately)
Plug: XM2A-0901
Hood: XM2S-0911
- D-sub 9P connectors for RS-232C output (K31-FLK4) (order separately)
Plug: XM2D-0901
Hood: XM2D-0911

K31-FLK3, -FLK6: RS-422

(The right connector is provided only on K31-FLK6)

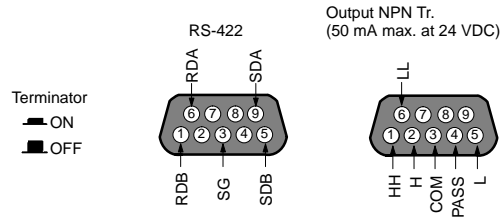

K31-FLK4: RS-232C + Transistor (NPN Open Collector)

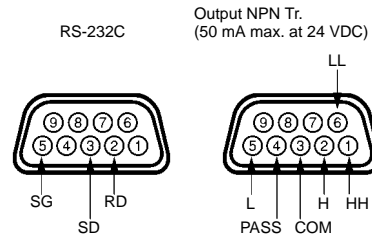

■ BCD Output Timing Chart

A request signal from an external device (such as a Programmable Controller) is required to read BCD data.

Single Sampling Data Output

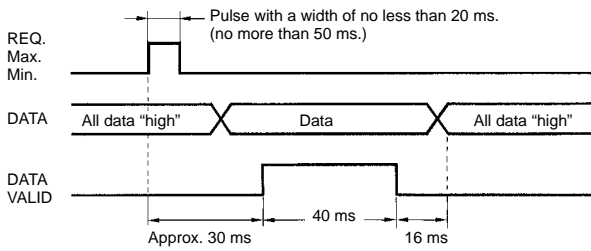

Approximately 30 ms after the REQ signal rises, a sample is taken and the DATA VALID signal is output. Read the data when the DATA VALID signal is ON.

The DATA VALID signal will turn OFF in 40 ms, and then in 16 ms, the data will go OFF.

Models with a BCD output have an open collector output configuration so that wired-OR connection is possible.

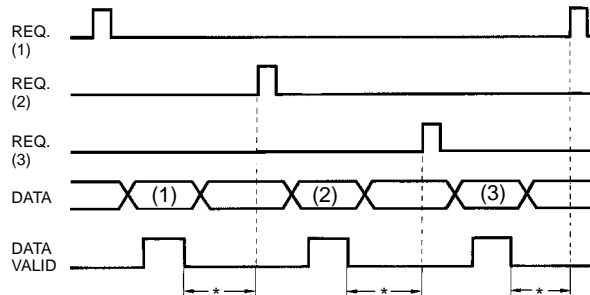
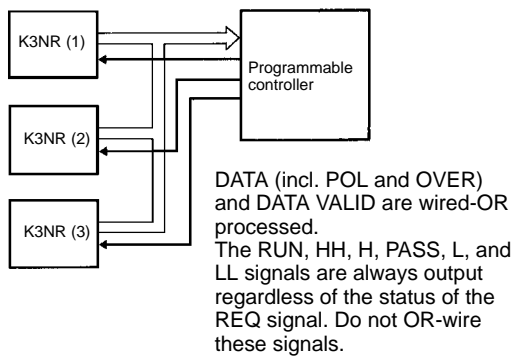

*The period between the DATA VALID signal and the REQ signal should be no less than 20 ms max.

Continuous Data Output

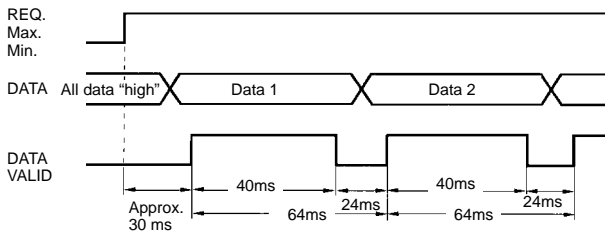

The K3NR outputs each measurement at an interval of 64 ms when a REQ signal is ON continuously.

If the HOLD signal is ON at the moment the DATA output is switched from Data 1 to Data 2 or vice versa, the output BCD data will be either Data 1 or Data 2 according to the timing of the HOLD signal. However, output data will never be below.

■ Output Operation Timing in RUN Mode (Relay or Transistor Outputs)

The following timing chart is for a 5-comparative Output Board when the standard output pattern is selected.

For Operating Mode 1 to 6

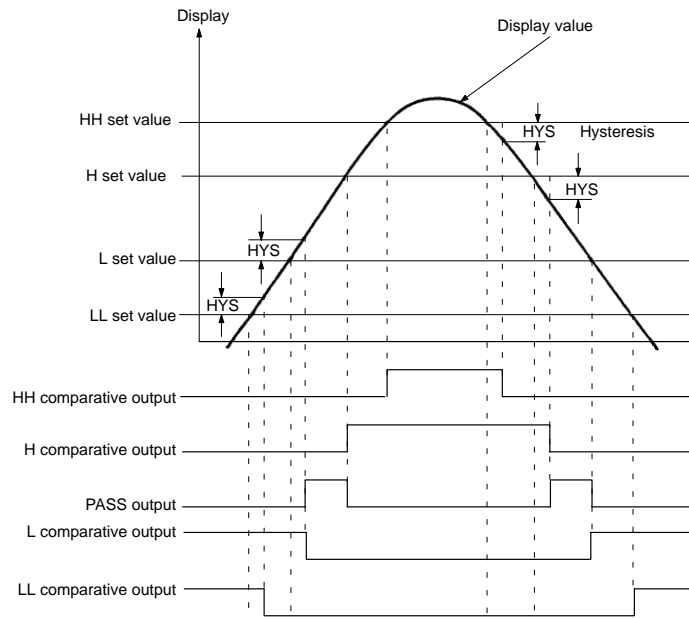

Note: The hysteresis is set in setting mode and the hysteresis value will be applied to all set values.

For Operating Mode 7

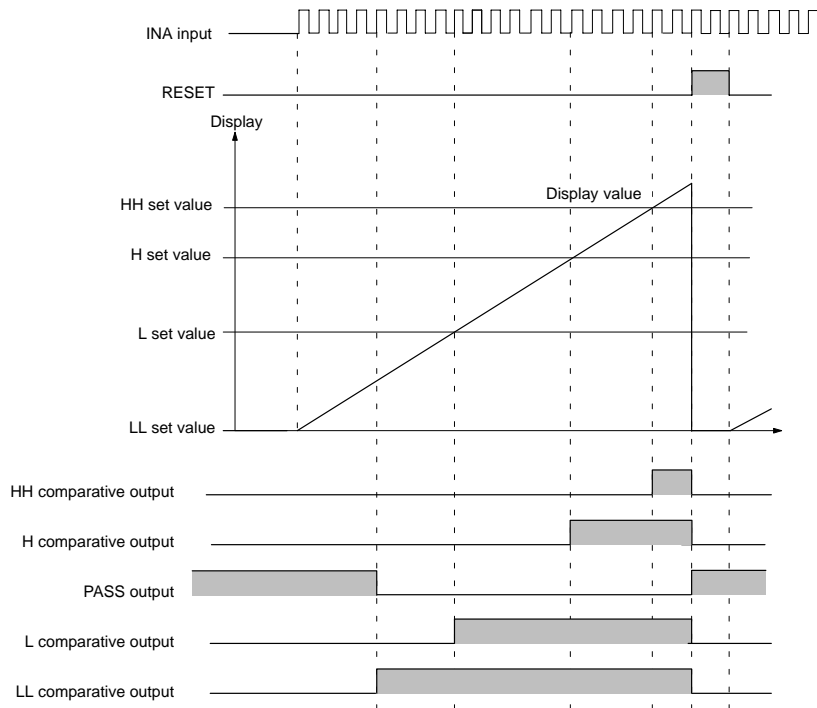

Note: Comparative output L or LL turns ON when the measured value exceeds the set value.

■ Operating Modes

The K3NR provides 7 operating modes for converting input pulses to display values. The mode can be selected via key operations on the front panel.

Basically, the operating modes can be divided into the following two groups.

Operating Modes 1 to 6

Rotational speed and other displays are based on calculations for continuous pulses (frequency).

Example

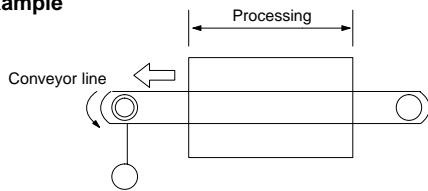

Operating mode no.	Use
01	Rotational/Circumferential speed
02	Absolute ratio
03	Error ratio
04	Rotation difference
05	Flow rate ratio
06	Passing time

Mode No. 1: Rotational or circumferential speed display for 1 input

Mode No. 2 to 5: Display of calculations for two rotational speeds

Mode No. 6: Passing time display based on 1 input frequency and processing length

Basic Principles of Rotational Speed Displays

The ON/OFF time (T) of a sensor input or other input is measured with the internal system clock to automatically calculate the frequency. This frequency is multiplied by 60 and displayed as a rotational speed.

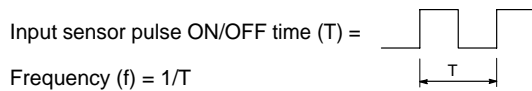

Rotational speed (rpm) = f x 60

Circumferential speed = Circumference x Rotational speed

Passing time = Processing length/Circumferential speed

Automatic measuring by the K3NR is enabled simply by providing an input pulse.

Operating Mode 7

The number of pulses is measured. Each pulse is counted as 1 count up to a maximum of 99,999 counts. Decrementing the count is not possible. Although the limits of the display enables displaying only up to 99,999 counts, prescaling can be used to count up to 4 gigacounts.

Operating mode no.	Use
07	Pulse counting

The count is reset by shorting terminals 6 and 7 (RESET ON) or by pressing the RESET/TEACH Key on the front panel

Because only incrementing is possible, the L and LL comparative outputs turn ON when the measured values exceed set values.

Operating Mode 1: Rotational/Circumferential Speed

The frequency of input A is calculated and displayed as a rotational or circumferential speed.

Units: rpm; rps; rph; Hz; kHz; mm/s; m/s; m/min; km/h; etc.

Application Example

Measuring Roller Winding Speed

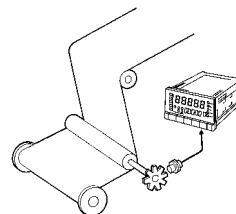

Measuring Motor Speed (for Product Testing)

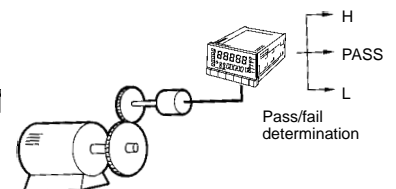

Operating Mode 2: Absolute Ratio

Input B is divided by input A (B/A) and then multiplied by 100 for display as a percentage.

Unit: %

Application Example

Measuring Ratio between Rotational Speed of Two Rollers

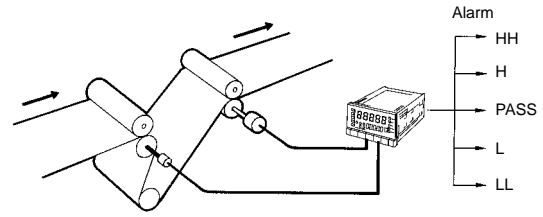

Operating Mode 3: Error Ratio

The error between input A and input B ($B/A - 1$) is multiplied by 100 for display as a percentage.

Unit: %

Application Example

Measuring Difference between Two Line Speeds (Two Conveyors)

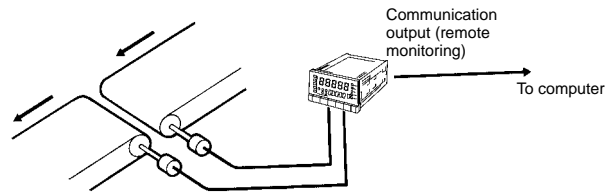

Operating Mode 4: Rotational Difference

The difference between input B and input A ($B - A$) is displayed as a rotational speed error or circumferential speed error.

Units: rpm; rps; rph; Hz; kHz; mm/s; m/s; m/min; km/h; etc.

Application Example

Measuring the Absolute Difference between the Speeds of Two Conveyors

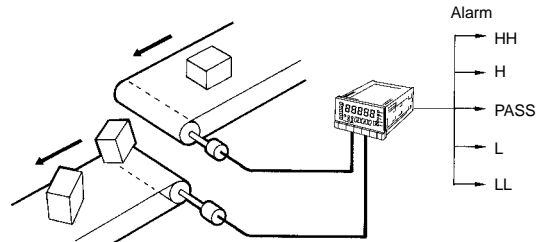

Operating Mode 5: Flow Rate Ratio

Input A and input B are used to find the concentration ($B/(A+B)$) as a percentage.

Unit: %

Application Example

Monitoring the Concentration of a Liquid Mixture

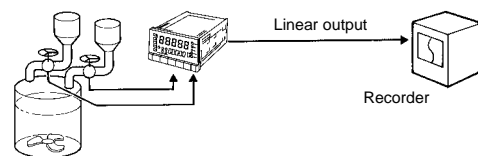

Operating Mode 6: Passing Time

The pulse frequency of input A is calculated and is displayed as the passing time for a preset distance.

Units: s; min; h, min, s; min, s, 1/10 s; etc.

The passing time measurement operation in operating mode 6 is ideal for measuring time corresponding to a frequency change. Operating mode 6 allows the real-time, continuous time measurement of the revolutions of any rotating object without recovery time.

Application Example

Passing Time for a Conveyor Line

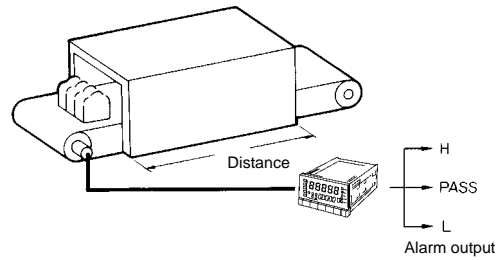

Operating Mode 7: Pulse Counting

The total number of pulses on input A is displayed.

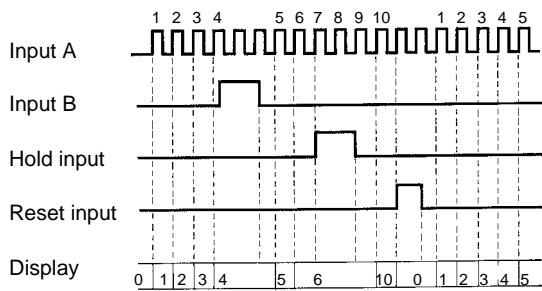

Units: count; mm; cm; m; l; kl; etc.

Application Example

Counting Workpieces

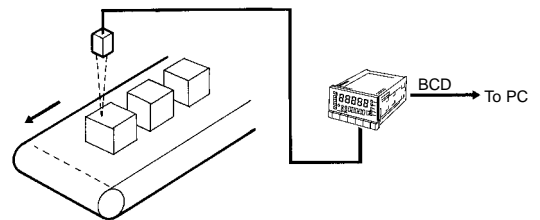

■ Block Diagram

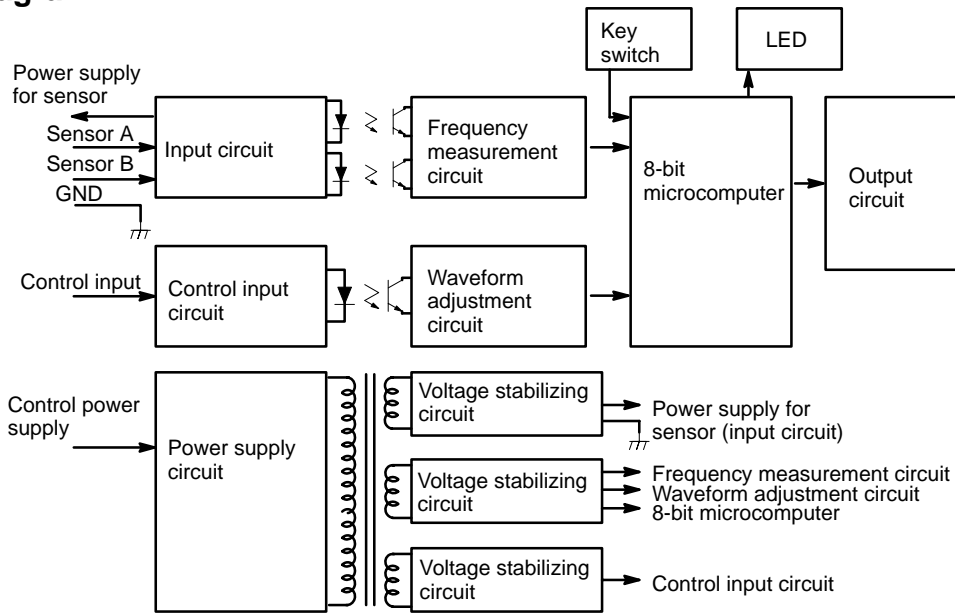

Dimensions

Note: All units are in millimeters unless otherwise indicated.

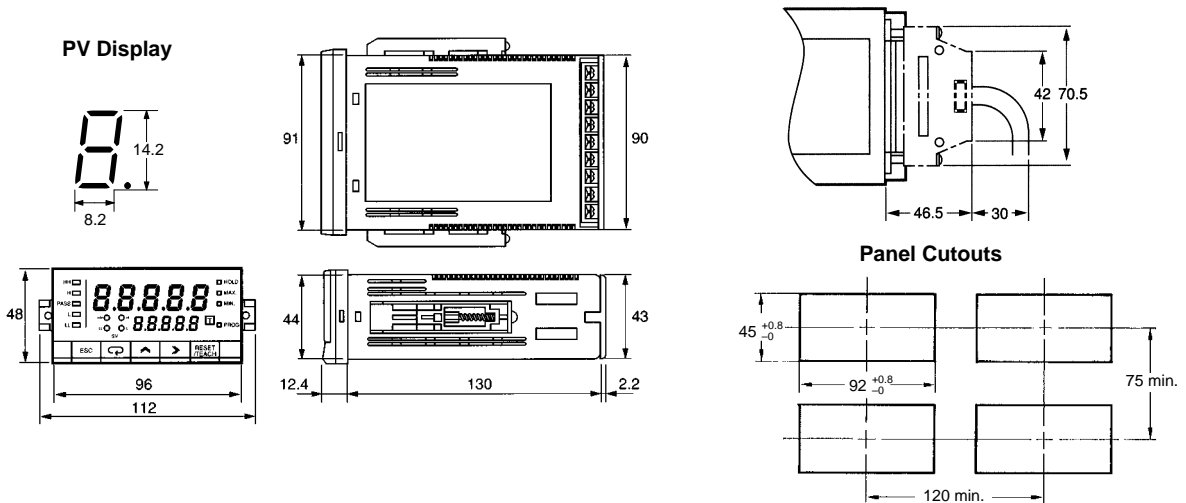

Installation

■ Example of Connection to Programmable Controller

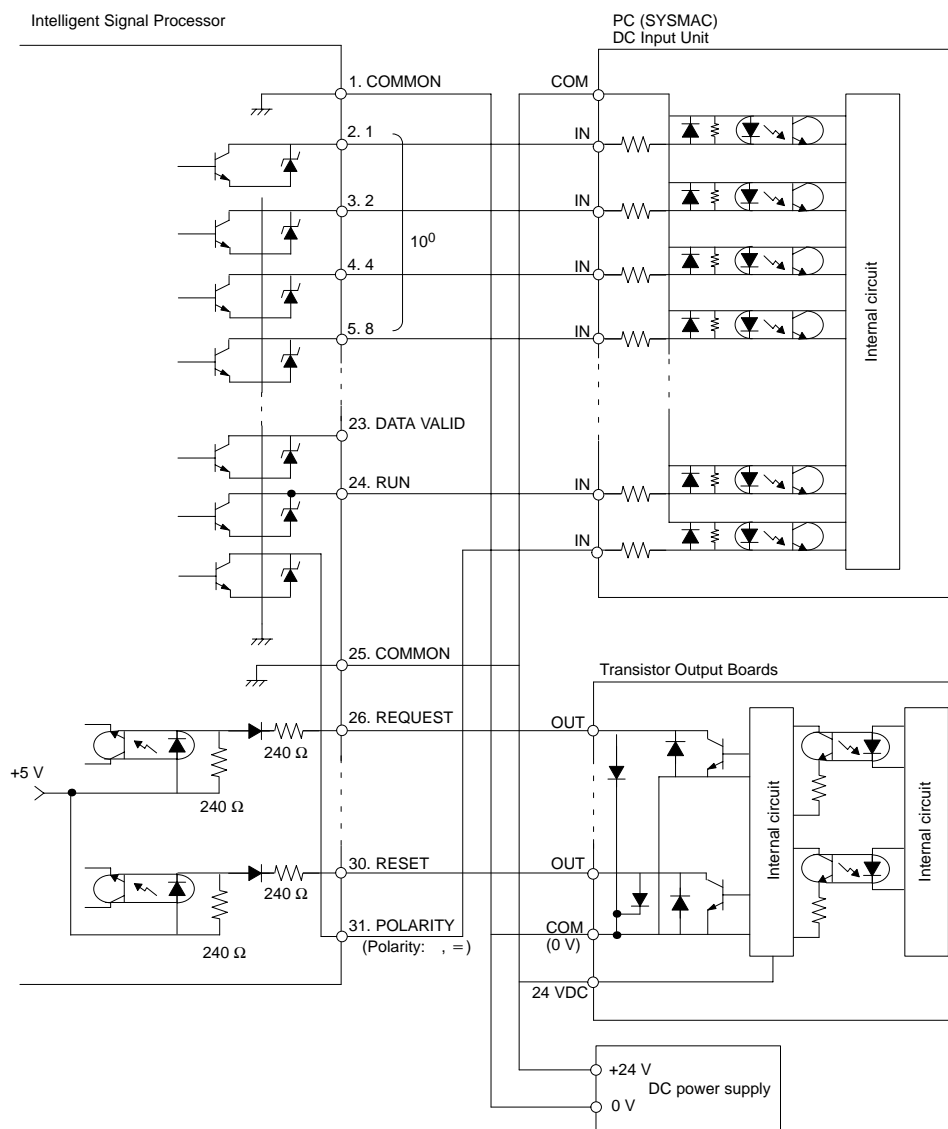

Precautions

- Be careful not to touch any terminals, otherwise you may receive an electric shock.
- Please do not disassemble the product nor touch the internal components of the product, otherwise you may receive an electric shock.
- Be sure that the power supply voltage is within the rated range.
- Do not use the Intelligent Signal Processor in locations with flammable gas or combustible substances.
- Be sure to wire the terminals correctly by checking the terminal names.
- Be sure that the terminal screws are tightened securely when wiring.

Mounting

Recommended panel thickness is 1 to 3.2 mm.

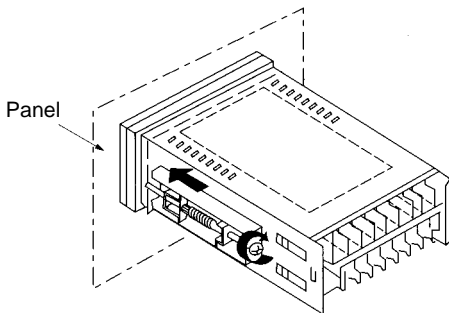

Attach the mounting bracket on the left and right sides of the Intelligent Signal Processor as shown in the illustration above and gradually tighten each screw evenly in turn by considering the balance of the tightening force until the ratchets start slipping without being further tightened.

Mount the Processor as horizontally as possible.

Never use the Processor in locations where corrosive gas (particularly sulfur or ammonia gas) is generated.

As much as possible avoid use of the Processor in a location subject to severe shock or vibration, excessive dust, or excessive moisture. Select an indoor mounting location where the Intelligent Signal Processor is at the rated temperature and humidity and free from direct sunlight.

Separate the Processor from machines generating high-frequency noise, such as high-frequency welding machines and high-frequency sewing machines.

Operation

A Processor model with a Relay Contact or Transistor Output Board may not output any alarm signal normally if the model has an error. It is recommended that an independent alarm device be connected to the model.

The parameters are factory-set so that the Processor will operate normally. The settings of the parameters may be changed according to the application.

ALL DIMENSIONS SHOWN ARE IN MILLIMETERS.

To convert millimeters into inches, multiply by 0.03937. To convert grams into ounces, multiply by 0.03527.

Unit Label (Attached)

No product is shipped with the unit label attached. Select a unit label from the sheet provided and attach it to the Processor.

A	A	mA	mA	V
V	mV	mV	W	KW
VA	KVA	var	Kvar	Ω
°C	°F	K	Hz	rpm
m	mm	cm	μm	Km
l	Kl	t	TON	lx
m ³	cm ³	mm ³	Kg	g
mg	Kg/m ³	g/cm ³	m ³ /Kg	m/s ²
G	N	mmHg	mmH ₂ O	Kgf/cm ²
Kgf/mm ²	J	KJ	Kgf-cm	gf-cm
PS	hp	cal	Kcal	Kg/h
t/h	Kg/s	m ³ /min	m ³ /h	m ³ /s
l/s	l/min	l/h	m/min	mm/s
m/s	%	dB	φ-mm	SCCM
sec	ms	min	counts	×10
×100	×1000	pH	ppm	pcs
deg	cP	cSt	KΩ	MΩ
KHZ	rps			
kV	s	m ²	cm ²	rad
S	S	L	kL	L/s
L/min	L/h	kN	mN	Pa
kPa	mPa	N·m	kN·m	mN·m
kg·m ²	lx	cps	°	rph
r/s	r/min	r/h	min ⁻¹	h ⁻¹
				h.min.s
min.s. 10s			omron	

Cat. No. N087-E1-1B In the interest of product improvement, specifications are subject to change without notice.

OMRON Corporation

Industrial Automation Company

Measuring and Supervisory Controls Department
Shiokoji Horikawa, Shimogyo-ku,
Kyoto, 600-8530 Japan
Tel: (81)75-344-7108/Fax: (81)75-344-7189

Printed in Japan
1200-0.5M (1297) (A)