

Miniature Basic Switch with Low Operating Force and High Contact Reliability

- Wide variation extends from micro load to 5-A switching current, with shapes identical to those of the V-series Miniature Basic Switch.
- A unique internal mechanism enables high contact strength with low operating force. Can be used for detecting lightweight objects.



Ordering Information

■ Model Number Legend

VX-□□-□□□

1 2 3 4 5

1. Ratings

- 5: 5 A at 250 VAC
- 01: 0.1 A at 125 VAC

2. Actuator

- None: Pin plunger
- 1: Short hinge lever
- 2: Hinge lever
- 3: Long hinge lever
- 4: Simulated roller lever
- 5: Short hinge roller lever
- 6: Hinge roller lever

3. Contact Form

- 1: SPDT
- 2: SPST-NC
- 3: SPST-NO

4. Terminal Specifications







- A: Solder/Quick-connect terminal (#187)
- C2: Quick-connect terminal (#187)

5. Operating Force max.

- 2: OF 0.25 N {25 gf}
- 3: OF 0.49 N {50 gf}

Note: These values are for the pin plunger model.

■ List of Models

Actuator	Terminals (see note)	OF max.	Model	
			5 A	0.1 A
Pin plunger 	A	0.25 N {25 gf}	VX-5-1A2	VX-01-1A2
		0.49 N {50 gf}	VX-5-1A3	VX-01-1A3
	C2	0.25 N {25 gf}	VX-5-1C22	VX-01-1C22
		0.49 N {50 gf}	VX-5-1C23	VX-01-1C23
Short hinge lever 	A	0.49 N {50 gf}	VX-51-1A3	VX-011-1A3
	C2	0.49 N {50 gf}	VX-51-1C23	VX-011-1C23
Hinge Lever 	A	0.29 N {30 gf}	VX-52-1A3	VX-012-1A3
	C2	0.29 N {30 gf}	VX-52-1C23	VX-012-1C23
Long hinge lever 	A	0.20 N {20 gf}	VX-53-1A3	VX-013-1A3
	C2	0.20 N {20 gf}	VX-53-1C23	VX-013-1C23
Simulated roller lever 	A	0.29 N {30 gf}	VX-54-1A3	VX-014-1A3
	C2	0.29 N {30 gf}	VX-54-1C23	VX-014-1C23
Short hinge roller lever 	A	0.59 N {60 gf}	VX-55-1A3	VX-015-1A3
	C2	0.59 N {60 gf}	VX-55-1C23	VX-015-1C23
Hinge roller lever 	A	0.29 N {30 gf}	VX-56-1A3	VX-016-1A3
	C2	0.29 N {30 gf}	VX-56-1C23	VX-016-1C23

Note: 1. Contact your OMRON representative for details on SPST-NO and SPST-NC models.

2. Terminals A: Solder/Quick-connect terminals (#187)
C2: Quick-connect terminals (#187)

Specifications

■ Ratings

Rated current	Rated voltage	Non-inductive load				Inductive load	
		Resistive load		Lamp load		NC	NO
		NC	NO	NC	NO		
5 A	125 VAC	5 A		0.5 A		4 A	
	8 VDC	5 A		3 A		4 A	
	30 VDC	5 A		3 A		4 A	
	125 VDC	0.4 A		0.1 A		0.4 A	
	250 VDC	0.3 A		0.05 A		0.2 A	
0.1 A	125 VAC	0.1 A		---		---	
	8 VDC	0.1 A		---		---	
	30 VDC	0.1 A		---		---	

Note: 1. Inductive load has a power factor of 0.4 min. (AC) and a time constant of 7 ms max. (DC).

2. Lamp load has an inrush current of 10 times the steady-state current.
3. The ratings values apply under the following test conditions:
Ambient temperature: 20±2°C
Ambient humidity: 65±5%
Operating frequency: 60 operations/min

■ Characteristics

Item	VX-5	VX-01
Operating speed	0.1 mm to 1 m/s (at pin plunger models)	
Operating frequency	Mechanical: 600 operations/min Electrical: 60 operations/min	
Insulation resistance	100 MΩ min. (at 500 VDC)	
Contact resistance	30 mΩ max. (initial value)	50 mΩ max. (initial value)
Dielectric strength	1,000 VAC, 50/60 Hz for 1 min between terminals of same polarity 1,500 VAC, 50/60 Hz for 1 min between current-carrying metal parts and ground (see note 1) 1,500 VAC, 50/60 Hz for 1 min between each terminal and non-current-carrying metal parts	
Vibration resistance (see note 2)	Malfunction: 10 to 55 Hz, 1.5-mm double amplitude	
Shock resistance (see note 2)	Destruction: 400 m/s ² {approx. 40G} max. Malfunction: 100 m/s ² {approx. 10G} max.	
Life expectancy	Mechanical: 50,000,000 operations min. (Refer to the following <i>Engineering Data</i> .) Electrical: 500,000 operations min. (Refer to the following <i>Engineering Data</i> .)	Mechanical: 10,000,000 operations min. (Refer to the following <i>Engineering Data</i> .) Electrical: 1,000,000 operations min. (Refer to the following <i>Engineering Data</i> .)
Degree of protection	IP00	
Degree of protection against electric shock	Class I	
Proof tracking index (PTI)	175	
Ambient temperature	Operating: -25°C to 80°C (at ambient humidity of 60% max.) (with no icing)	
Ambient humidity	Operating: 85% max. (for 5°C to 35°C)	
Weight	Approx. 6.2 g (pin plunger models)	

Note: 1. The value for dielectric strength shown is for models with a Separator.

2. For the pin plunger models, the above values apply for use at both the free position and total travel position. For the lever models, they apply at the total travel position. Contact opening or closing time is within 1 ms.

■ Approved Standards

UL1054 (File No. E41515)

CSA C22.2 No.55 (File No. LR21642)

Rated voltage	VX-5	VX-01
125 VAC	5 A	0.1 A
250 VAC	5 A	---
30 VDC	---	0.1 A

VDE 0630 (File No. 90430)

SEMKO (File No. 8920075)

Rated voltage	VX-5	VX-01
125 VAC	5 A	0.1 A
250 VAC	5 A	---

Note: Testing conditions: 50,000 operations, T105 (0°C to 105°C)

■ Contact Specifications

Item	VX-5	VX-01
Contact	Specification	Rivet
	Material	Silver alloy
	Gap (standard value)	0.5 mm
Inrush current	NC	15 A max.
	NO	---
Minimum applicable load	160 mA at 5 VDC	1 mA at 5 VDC

■ Contact Form

SPDT

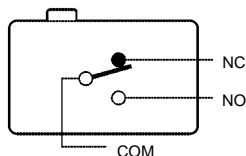

SPST-NC

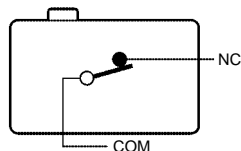

SPST-NO

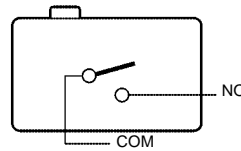

Engineering Data

Mechanical Life Expectancy (Pin Plunger)

VX-5

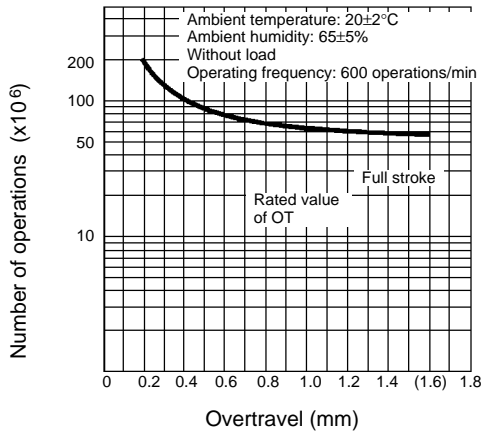

VX-01

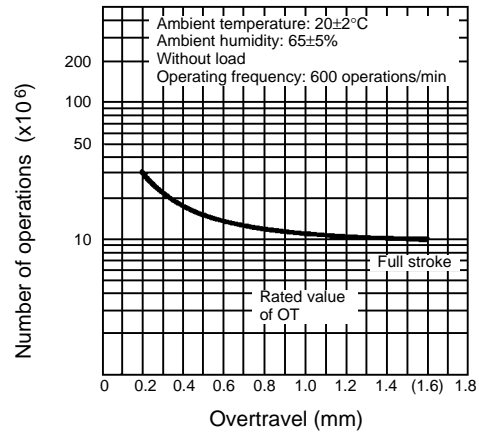

Electrical Life Expectancy

VX-5

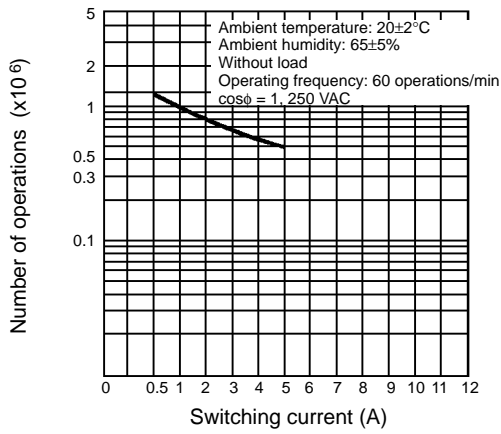

VX-01

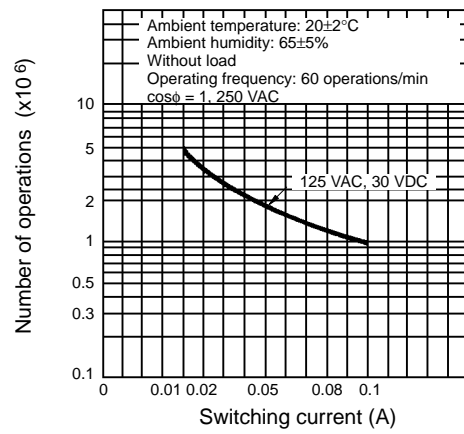

Dimensions

■ Terminals

- Note:** 1. All units are in millimeters unless otherwise indicated.
 2. The following is for the SPDT contact specifications.

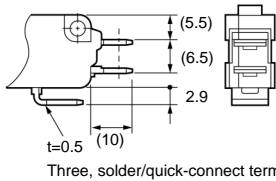
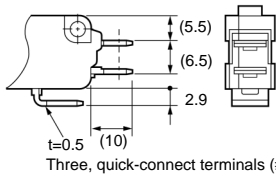
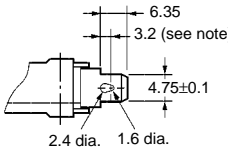
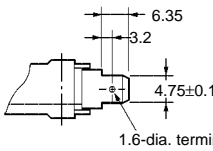
Terminal	Solder/Quick-connect terminal (#187) (A terminal)	Quick-connect terminal (#187) (C2 terminal)
COM terminal position is bottom.		
Terminal dimension		

■ Mounting Holes

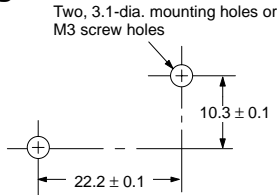

■ Dimensions and Operating Characteristics

- Note:** 1. All units are in millimeters unless otherwise indicated.
 2. Unless otherwise specified, a tolerance of ± 0.4 mm applies to all dimensions.
 3. The following illustrations and drawings are for solder/quick-connect terminals (#187) (Terminal A). Illustrations for Terminal C2 are omitted. For details, refer to *Terminals*.
 4. The □ in the model number is for the terminal code.
 A: Solder/quick-connect terminal (#187)
 C2: Quick-connect terminal (#187)
 5. The operating characteristics are for operation in the A direction (▼).

Pin Plunger

- VX-5-1□2
 VX-5-1□3
 VX-01-1□2
 VX-01-1□3

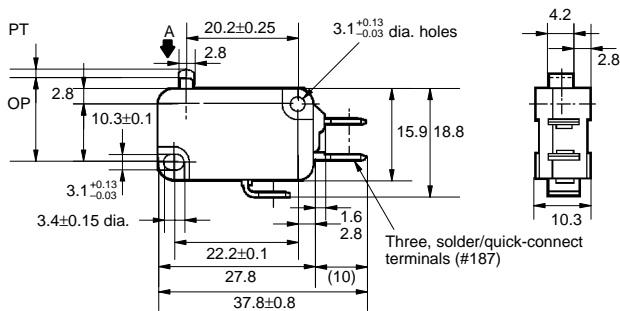
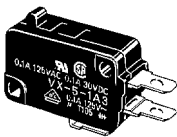

Model	VX-5-1□2 VX-01-1□2	VX-5-1□3 VX-01-1□3
OF max.	0.25 N {25 gf}	0.49 N {50 gf}
RF min.	0.03 N {3 gf}	0.05 N {5 gf}
PT max.	1.2 mm	
OT min.	1.0 mm	
MD max.	0.3 mm	
OP	14.7±0.4 mm	

Short Hinge Lever

- VX-51-1□3
 VX-011-1□3

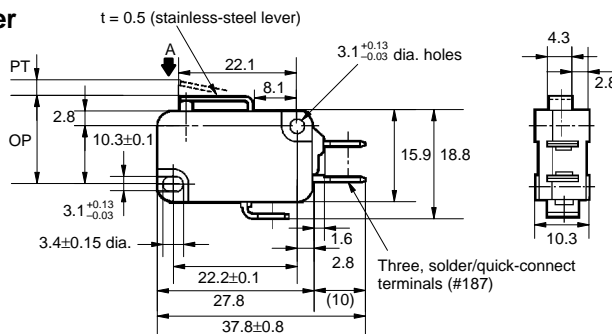
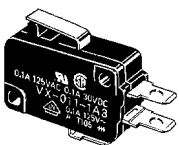

Model	VX-51-1□3	VX-011-1□3
OF max.	0.49 N {50 gf}	
RF min.	0.04 N {4 gf}	
PT max.	1.6 mm	
OT min.	0.8 mm	
MD max.	0.5 mm	
OP	15.2±0.5 mm	

Hinge Lever

VX-52-1□3
VX-012-1□3

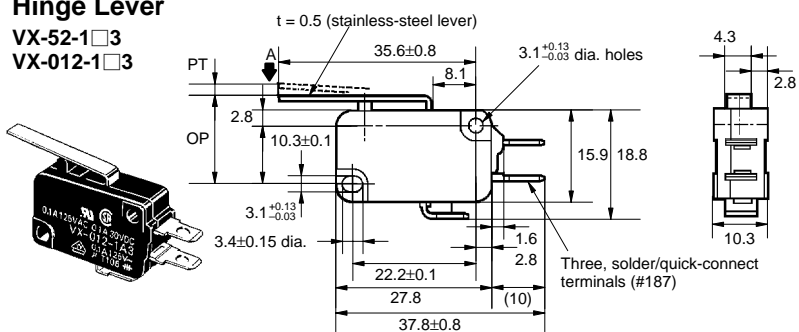

Model	VX-52-1□3	VX-012-1□3
OF max.	0.29 N {30 gf}	
RF min.	---	
PT max.	4.0 mm	
OT min.	1.6 mm	
MD max.	0.8 mm	
OP	15.2±1.2 mm	

Long Hinge Lever

VX-53-1□3
VX-013-1□3

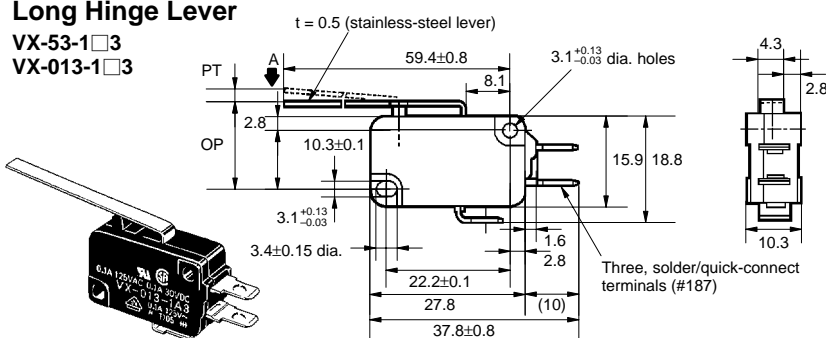

Model	VX-53-1□3	VX-013-1□3
OF max.	0.20 N {20 gf}	
RF min.	---	
PT max.	9.0 mm	
OT min.	3.2 mm	
MD max.	2.0 mm	
OP	15.2±2.6 mm	

Simulated Roller Lever

VX-54-1□3
VX-014-1□3

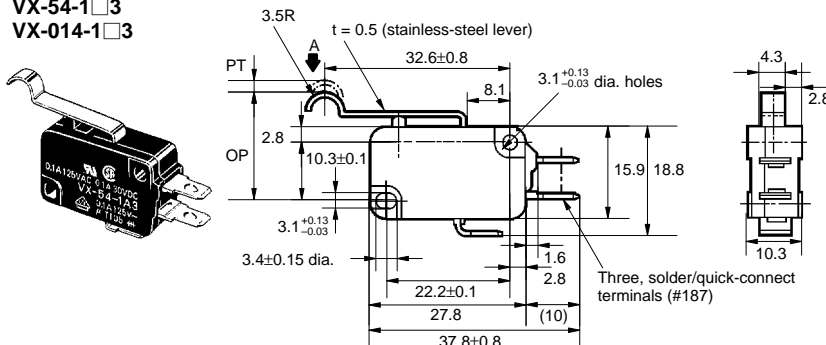

Model	VX-54-1□3	VX-014-1□3
OF max.	0.29 N {30 gf}	
RF min.	0.02 N {2 gf}	
PT max.	4.0 mm	
OT min.	1.6 mm	
MD max.	0.8 mm	
OP	18.7±1.2 mm	

Short Hinge Roller Lever

VX-55-1□3
VX-015-1□3

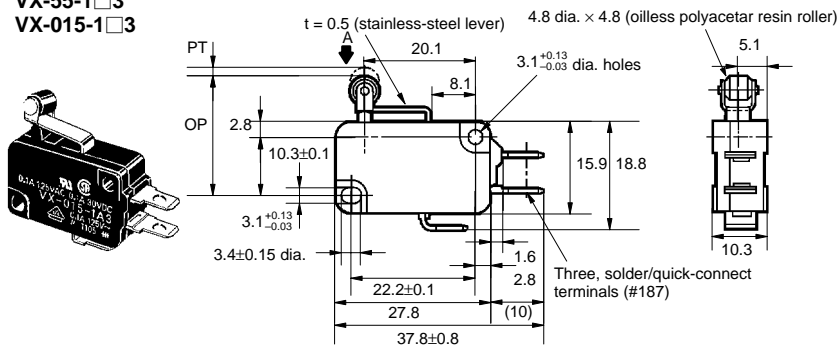

Model	VX-55-1□3	VX-015-1□3
OF max.	0.59 N {60 gf}	
RF min.	(0.04 N {4 gf})	
PT max.	1.6 mm	
OT min.	0.8 mm	
MD max.	0.5 mm	
OP	20.7±0.6 mm	

Note: The values indicated in parentheses are reference values for cases when the installation direction is such that the lever weight is not applied to the plunger.

Hinge Roller Lever

VX-56-1□3
VX-016-1□3

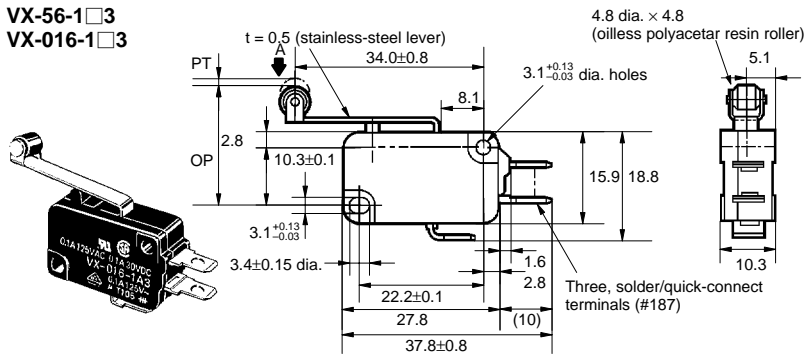

Model	VX-56-1□3	VX-016-1□3
OF max.	0.29 N {30 gf}	
RF min.	---	
PT max.	4.0 mm	
OT min.	1.6 mm	
MD max.	0.8 mm	
OP	20.7±1.2 mm	

Precautions

Refer to pages 26 to 33 for common precautions.

■ **Cautions**

Handling

Be careful not to drop the Switch. Doing so may cause damage to the Switch's internal components because it is designed for a small load.

■ **Correct Use**

Mounting

Use M3 mounting screws with plane washers or spring washers to securely mount the Switch. Tighten the screws to a torque of 0.39 to 0.59 N • m {4 to 6 kgf • cm}.

Mounting Direction

For a Switch with an actuator, mount the Switch in a direction where the actuator weight will not be applied to the Switch. Since the Switch is designed for a small load, its resetting force is small. Therefore, resetting failure may occur if unnecessary load is applied to the Switch.

Operating Temperature

Do not use the Switch under a high temperature. The thermal plastic resin used for the housing may deteriorate if exposed to a high temperature.

Using Micro Loads

Using a model for ordinary loads to open or close the contact of a micro load circuit may result in faulty contact. Use models that operate in the following range. However, even when using micro load models within the operating range shown below, if inrush current occurs when the contact is opened or closed, it may increase contact wear and so decrease life expectancy. Therefore, insert a contact protection circuit where necessary.

The minimum applicable load is the N-level reference value. This value indicates the malfunction reference level for the reliability level of 60% ($\lambda 60$). The equation, $\lambda 60 = 0.5 \times 10^{-6}/\text{operations}$ indicates that the estimated malfunction rate is less than 1/2,000,000 operations with a reliability level of 60%.

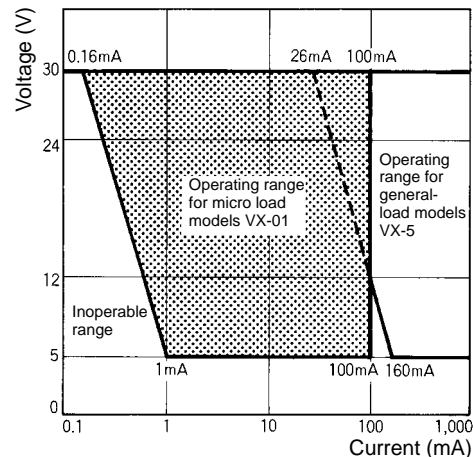

■ **Actuator (Sold Separately)**

Various Actuators are available as shown on pages 139 to 142.

■ **Connector (Sold Separately)**

Refer to Terminal Connectors on page 238.

ALL DIMENSIONS SHOWN ARE IN MILLIMETERS.
To convert millimeters into inches, multiply by 0.03937. To convert grams into ounces, multiply by 0.03527.