

Subminiature Models Capable of Large-capacity Loads

- Snap-action switch allows large-capacity switching (7 A at 250 VAC) in spite of its small size (8.9 × 12.7 × 5.1 mm).
- Particularly suitable as control switches for applications where there are restrictions on installation space and weight.
- Easy positioning, as the pin plunger is located in alignment with the center line of one of the two mounting holes.

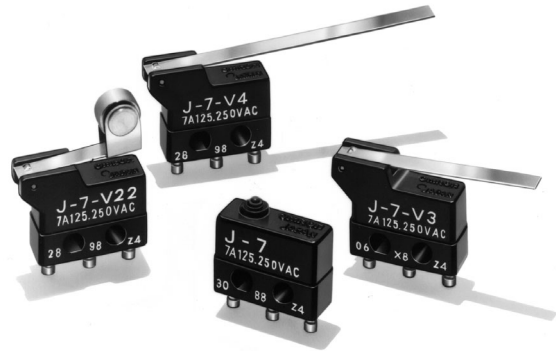

Ordering Information

Model Number Legend

J-7 -

1 2 3

1. Ratings

7: 7 A at 250 VAC

2. Contact Material

None: Gold-plated silver

Y: Silver

3. Actuator

None: Pin plunger

V: Short hinge lever







V3: Hinge lever

V4: Long hinge lever

V22: Short hinge roller lever

V2: Hinge roller lever

List of Models

Actuator	Model
Pin plunger 	J-7
Short hinge lever 	J-7-V
Hinge lever 	J-7-V3
Long hinge lever 	J-7-V4
Short hinge roller lever 	J-7-V22
Hinge roller lever 	J-7-V2

Note: Externally mounted levers JAL and JAL2 are sold separately. Refer to page 208.

Specifications

■ Ratings

Rated voltage	Resistive load
125 VAC	7 A
250 VAC	7 A

Note: The ratings values apply under the following test conditions:
 Ambient temperature: 20±2°C
 Ambient humidity: 65±5%
 Operating frequency: 30 operations/min

■ Switching Capacity per Load (Reference Values)

Voltage	Non-inductive load				Inductive load			
	Resistive load		Lamp load		Inductive load		Motor load	
	NC	NO	NC	NO	NC	NO	NC	NO
125 VAC	7 A		1.5 A	0.7 A	4 A		2.5 A	1.3 A
250 VAC	7 A		1.5 A	0.7 A	4 A		2.5 A	1.3 A
8 VDC	7 A		1.5 A	0.7 A	3 A		2.5 A	1.3 A
14 VDC	7 A		1.5 A	0.7 A	3 A		2.5 A	1.3 A
30 VDC	5 A		1.5 A	0.7 A	3 A		2.5 A	1.3 A
125 VDC	0.4 A		0.4 A	0.4 A	0.03 A		0.03 A	0.03 A
250 VDC	0.2 A		0.2 A	0.2 A	0.02 A		0.02 A	0.02 A

Note: 1. The above values are for the steady-state current.
 2. Inductive load has a power factor of 0.4 min. (AC) and a time constant of 7 ms max. (DC).
 3. Lamp load has an inrush current of 10 times the steady-state current.
 4. Motor load has an inrush current of 6 times the steady-state current.

■ Characteristics

Operating speed	0.05 mm to 1 m/s (pin plunger models)
Operating frequency	Mechanical: 400 operations/min max. Electrical: 30 operations/min max.
Insulation resistance	100 MΩ min. (at 500 VDC)
Contact resistance (initial value)	15 mΩ max.
Dielectric strength	600 VAC, 50/60 Hz for 1 min between terminals of the same polarity 1,500 VAC, 50/60 Hz for 1 min between each terminal and non-current-carrying metal part and between current-carrying metal part and ground.
Vibration resistance (see note 2)	Malfunction: 10 to 55 Hz, 1.5-mm double amplitude
Shock resistance (see note 2, 3)	Destruction: 1,000 m/s ² {approx. 100G} max. Malfunction: 200 m/s ² {approx. 20G} max. (pin plunger models)
Durability (see note 4)	Mechanical: 10,000,000 operations min. (60 operations/min) Electrical: 50,000 operations min. (30 operations/min)
Degree of protection	IEC IP40
Degree of protection against electric shock	Class I
Proof tracking index (PTI)	175
Ambient operating temperature	-10°C to 80°C (at ambient humidity of 60% max.) (with no icing)
Ambient operating humidity	85% max. (for 5°C to 35°C)
Weight	Approx. 1 g (pin plunger models)

Note: 1. The data given above are initial values.
 2. Malfunction: 1 ms max.
 3. For the pin plunger models, the values are at the free position and total travel position. For the lever models, they are at the total travel position.
 4. For testing conditions, consult your OMRON sales representative.

■ **Approved Standards**

Consult your OMRON sales representative for specific models with standard approvals.

**UL508 (File No. E41515)/
CSA C22.2 No. 55 (File No. LR21642)**

Rated voltage	J-7
125 VAC	7 A
250 VAC	

■ **Contact Form**

SPDT

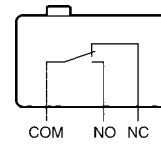

■ **Contact Specifications**

Contact	Specification	Rivet
	Material	Silver plated Gold plated
	Gap (standard value)	0.35 mm
	Inrush current	NC NO
Minimum applicable load		30 mA at 5 VDC

Engineering Data (Reference Values)

Mechanical Durability

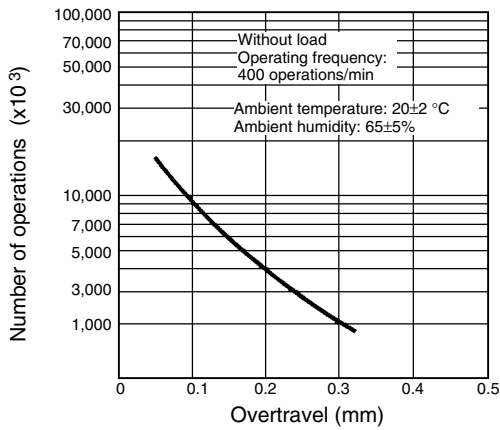

Electrical Durability

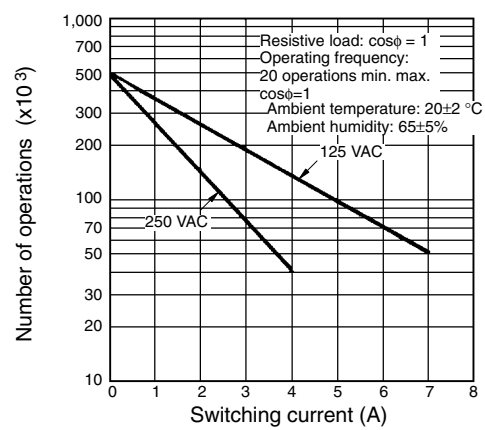

Dimensions

■ Mounting Holes

Note: All units are in millimeters unless otherwise indicated.

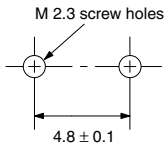

■ Dimensions and Operating Characteristics

- Note:**
1. All units are in millimeters unless otherwise indicated.
 2. Unless otherwise specified, a tolerance of ±0.2 mm applies to all dimensions.
 3. The operating characteristics are for operation in the A direction (▼).

Pin Plunger Models

J-7

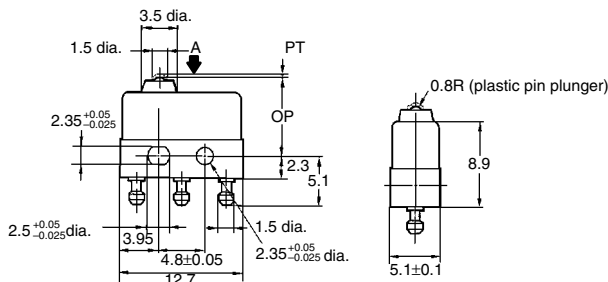
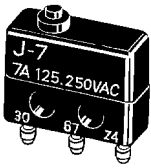

Model	J-7
OF max.	1.37 N {140 gf}
RF min.	0.27 N {28 gf}
PT max.	0.6 mm
OT min.	0.1 mm
MD max.	0.15 mm
OP	8.1±0.3 mm

Short Hinge Lever Models

J-7-V

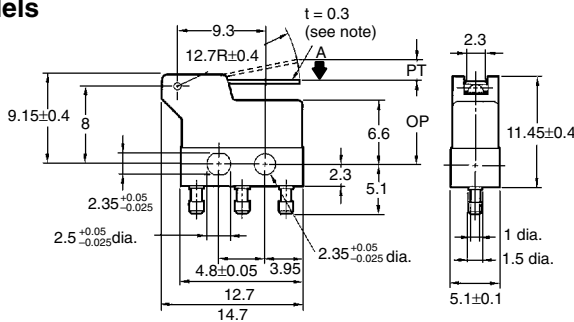
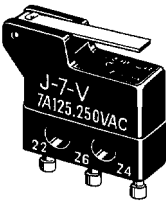

Model	J-7-V
OF max.	0.49 N {50 gf}
RF min.	0.08 N {9 gf}
PT max.	1.7 mm
OT min.	0.35 mm
MD max.	0.5 mm
OP	8.3±1.2 mm

Note: Stainless-steel spring lever

Hinge Lever Models

J-7-V3

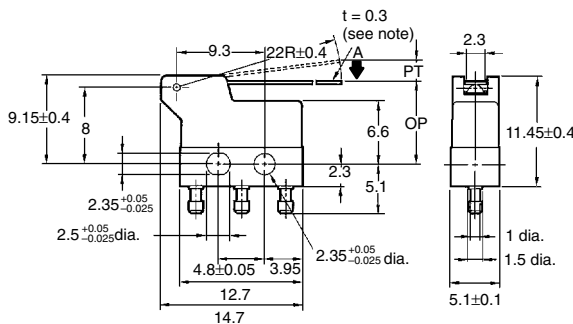
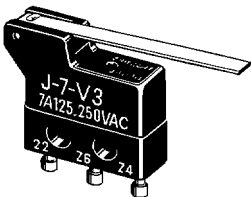

Model	J-7-V3
OF max.	0.29 N {30 gf}
RF min.	0.04 N {5 gf}
PT max.	2.9 mm
OT min.	0.5 mm
MD max.	0.7 mm
OP	8.3±1.9 mm

Note: Stainless-steel spring lever

Long Hinge Lever Models
J-7-V4

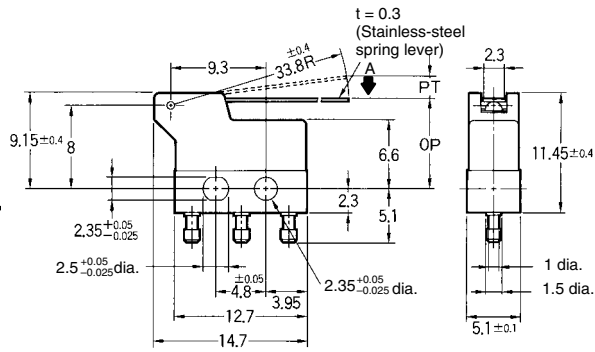
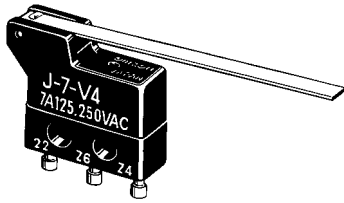

Model	J-7-V4
OF max.	0.20 N {20 gf}
RF min.	0.02 N {3 gf}
PT max.	4.5 mm
OT min.	0.8 mm
MD max.	1.2 mm
OP	8.3±2.9 mm

Short Hinge Roller Lever Models
J-7-V22

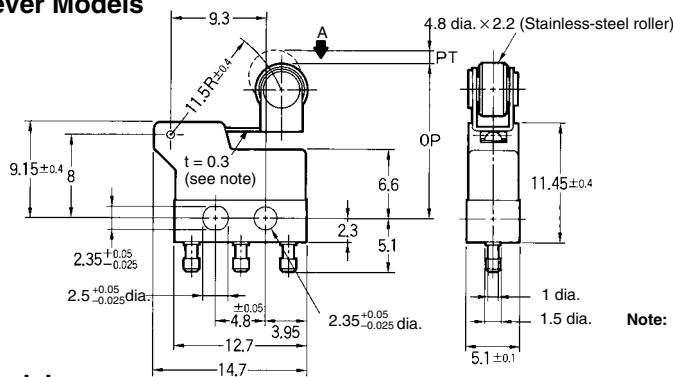
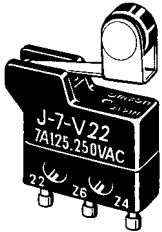

Model	J-7-V22
OF max.	0.54 N {55 gf}
RF min.	0.04 N {5 gf}
PT max.	1.6 mm
OT min.	0.25 mm
MD max.	0.4 mm
OP	14.7±1 mm

Note: Stainless-steel spring lever

Hinge Roller Lever Models
J-7-V2

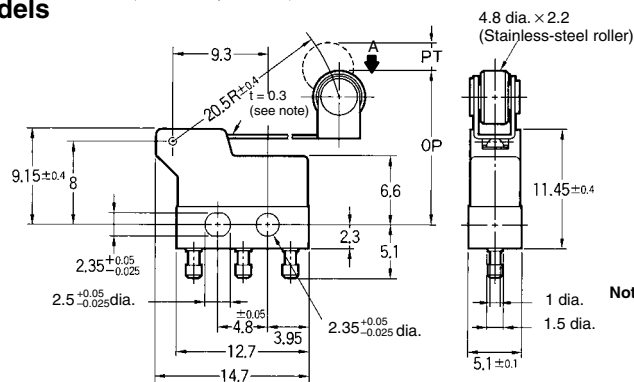
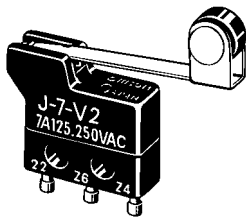

Model	J-7-V2
OF max.	0.324 N {33 gf}
RF min.	0.02 N {3 gf}
PT max.	2.7 mm
OT min.	0.45 mm
MD max.	0.7 mm
OP	14.7±1.9 mm

Note: Stainless-steel spring lever

Accessories (Sold Separately)

Actuators

Leaf Spring

JAL

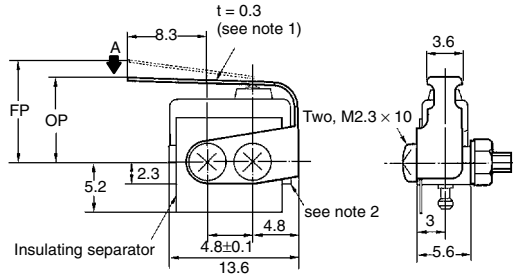
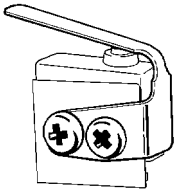

Model	JAL
OF max.	1.95 N {199 gf}
RF min.	0.54 N {56 gf}
PT max.	5.2 mm (reference value)
OT min.	0.3 mm
MD max.	0.8 mm
FP max.	13.1 mm
OP	8.7±0.8 mm

Note: 1. Stainless-steel spring lever
2. J-7 Subminiature Basic Switch

JAL2

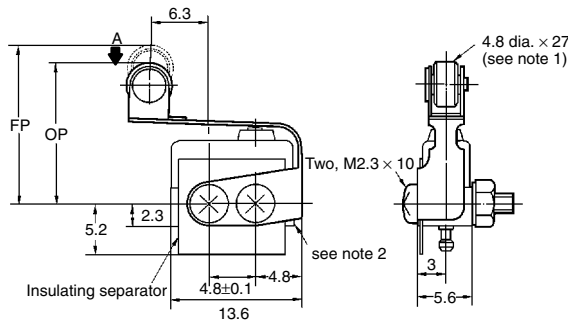
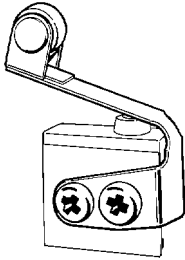

Model	JAL2
OF max.	1.95 N {199 gf}
RF min.	0.54 N {56 gf}
PT max.	3.6 mm (reference value)
OT min.	0.3 mm
MD max.	0.8 mm
FP max.	19.5 mm
OP	15.1±0.8 mm

Note: 1. Stainless-steel spring lever
2. J-7 Subminiature Basic Switch

Precautions

Refer to pages 26 to 31 for common precautions.

■ Correct Use

Mounting

Use two M2.3 screws with plain washers or spring washers to securely mount the Switch. Tighten the screws to a torque of 0.19 to 0.29 N • m {2 to 3 kgf • cm}.

Soldering

To solder the lead to the terminal, apply a soldering iron rated at 30 W max. quickly (within 3 seconds) with the actuator at the free position.

Applying a soldering iron for too long a time or using one that is rated at more than 30 W may degrade the Switch characteristics.

ALL DIMENSIONS SHOWN ARE IN MILLIMETERS.
To convert millimeters into inches, multiply by 0.03937. To convert grams into ounces, multiply by 0.03527.