

Solid-state Relay

G3R/G3RD

Compact SSRs Ideal for Built-in Applications

- Vertical, compact SSRs with an operation indicator offered in versatile variations.
- High dielectric strength of 2,500 VAC for 2-A models.
- High-voltage DC version also available.
- Approved by UL and CSA.



Ordering Information

Terminals	Isolation	Zero cross function	Indicator	Rated output load (Applicable output load)	Rated input voltage	Model	
PCB	Phototriac	Yes		2 A at 100 to 120 VDC (2 A at 75 to 132 VDC) (see note 1)		G3R-102PN-US	
		No				G3R-102PLN-US	
		Yes				2 A at 100 to 240 VAC (2 A at 75 to 264 VAC) (see note 2)	G3R-202PN-US
		No					G3R-202PLN-US
	Photocoupler	---	Yes	1.5 A at 5 to 110 VDC (1.5 A at 3 to 125 VDC)		G3RD-101PN-US	
				2 A at 4 to 48 VDC (2 A at 3 to 52.8 VDC) (see note 3)		G3RD-X02PN-US	

- Note:**
1. Product is labelled "125 VAC".
 2. Product is labelled "250 VAC".
 3. Product is labelled "50 VDC".

Specifications

■ Ratings

Input (AC Output With Zero Cross Function)

Model	Rated voltage	Operating voltage	Impedance	Voltage level	
				Must operate voltage	Must release voltage
G3R-102PN	5 VDC	4 to 6 VDC	250 $\Omega \pm 20\%$	3.5 VDC max.	0.375 VDC min.
G3R-202PN	12 VDC	9.6 to 14.4 VDC	600 $\Omega \pm 20\%$	8.4 VDC max.	0.9 VDC min.
	24 VDC	19.2 to 28.8 VDC	1.5 k $\Omega \pm 20\%$	16.8 VDC max.	1.8 VDC min.

Input (AC Output Without Zero Cross Function, DC Output)

Model	Rated voltage	Operating voltage	Impedance	Voltage level	
				Must operate voltage	Must release voltage
G3R-102PLN	5 VDC	4 to 6 VDC	300 $\Omega \pm 20\%$	3.5 VDC max.	0.375 VDC min.
G3R-202PLN	12 VDC	9.6 to 14.4 VDC	750 $\Omega \pm 20\%$	8.4 VDC max.	0.9 VDC min.
G3RD-X02PN G3RD-101PN	24 VDC	19.2 to 28.8 VDC	1.5 k $\Omega \pm 20\%$	16.8 VDC max.	1.8 VDC min.

Output

Model	Rated load voltage	Applicable load		
		Load voltage range	Load current	Inrush current
G3R-102PN G3R-102PLN	100 to 120 VAC	75 to 132 VAC	0.1 to 2 A	30 A (60 Hz, 1 cycle)
G3R-202PN G3R-202PLN	100 to 240 VAC	75 to 264 VAC	0.1 to 2 A	
G3RD-X02PN	4 to 48 VDC	3 to 52.8 VDC	0.01 to 2 A	8 A (10 ms)
G3RD-101PN	5 to 110 VDC	3 to 125 VDC	0.01 to 1.5 A	2.5 A (10 ms)

■ Characteristics

Item	G3R-102PLN	G3R-102PN	G3R-202PLN	G3R-202PN	G3RD-X02PN/-101PN
Operate time	1 ms max.	1/2 of load power source cycle + 1 ms max.	1 ms max.	1/2 of load power source cycle + 1 ms max.	1 ms max.
Release time	1/2 of load power source cycle + 1 ms max.				1 ms max.
Output ON voltage drop	1.6 V (RMS) max.				1.5 V max.
Leakage current	2 mA max. (at 100 VAC)		2 mA max. (at 100 VAC) 5 mA max. (at 200 VAC)		0.1 mA max. (at 125 VDC) 0.1 mA max. (at 50 VDC)
Insulation resistance	100 M Ω min. (at 500 VDC)				
Dielectric strength	2,500 VAC, 50/60 Hz for 1 min				2,500 VAC, 50/60 Hz for 1 min
Vibration resistance	Malfunction: 10 to 55 Hz, 1.5-mm double amplitude				
Shock resistance	Malfunction: 1,000 m/s ²				
Ambient temperature	Operating: -30°C to 80°C (with no icing or condensation) Storage: -30°C to 100°C (with no icing or condensation)				
Approved standards	UL508 File No. E64562, CSA C22.2 (No. 14) File No. 35535				
Ambient humidity	Operating: 45% to 85%				
Weight	Approx. 18 g				

■ Approved Standards

UL508 File No. E64562/CSA C22.2 (No.0, No.14) File No. LR35535

Model	Ratings
G3R-102P(L)(N)-US	2 A at 125 VAC
G3R-202P(L)(N)-US	2 A at 250 VAC
G3RD-X02P(N)-US	2 A at 50 VDC

Engineering Data

Load Current vs. Ambient Temperature Characteristics

1-A Load Model

G3RD-101PN

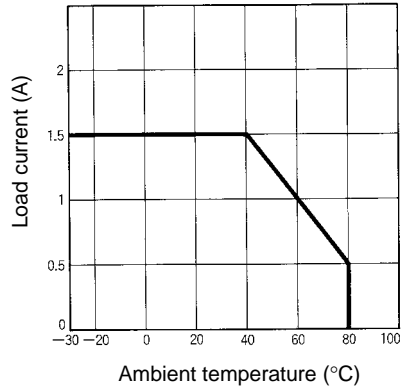

2-A Load Model

G3R-102□, G3RD-X02□, G3R-202□

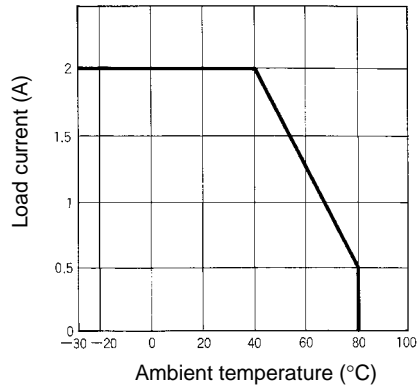

Inrush Current Resistivity

Non-repetitive (Keep the inrush current to half the rated value if it occurs repetitively.)

G3R-102□/202□

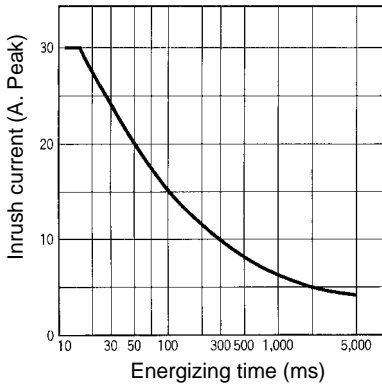

G3RD-101PN

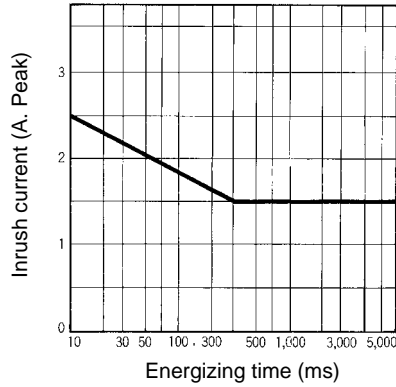

G3RD-X02□

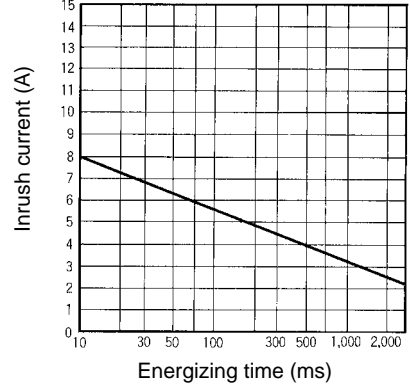

Dimensions

Note: All units are in millimeters unless otherwise indicated.

G3R-102P□/-202P□
G3RD-101PN/-X02PN

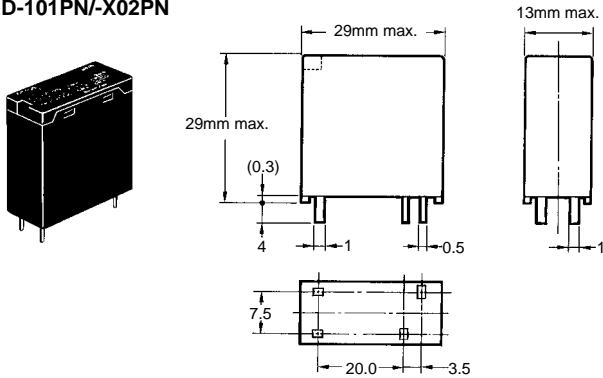

Terminal Arrangement/ Internal Connections (Bottom View)

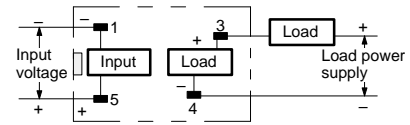

Note: The plus and minus symbols shown in the parentheses are for DC loads.

Mounting Holes

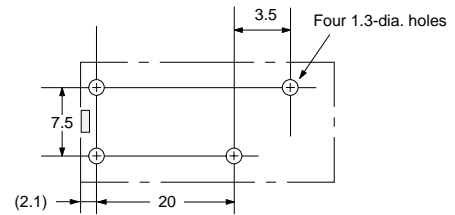

Precautions

Connection

The SSR for DC switching a surge can connect to a load regardless of the polarity of the positive and negative output terminals.

Protective Terminal

For AC inductive loads, connect the load terminals of the SSR to a surge absorber (varistor).

ALL DIMENSIONS SHOWN ARE IN MILLIMETERS.

To convert millimeters into inches, multiply by 0.03937. To convert grams into ounces, multiply by 0.03527.